

TECHNICAL MANUAL

**COOLING SYSTEMS:
TACTICAL VEHICLES**

This reprint includes all changes in effect at the time of publication - Changes 1 and 2.

HEADQUARTERS, DEPARTMENT OF THE ARMY

29 MARCH 1972

WARNING

There is danger to personnel from hot blowing solder. Wear safety goggles, rubber gloves and rubber apron while blowing solder.

WARNING

If hot cleaning vat solution, muriatic acid or flux enters the eyes, wash generously for 15 minutes with clean water. Seek medical attention.

WARNING

When working with the hot cleaning vat, safety goggles, rubber shoes, rubber apron and gloves should be worn for protection against hot vat solution.

WARNING

Flux, caustic solutions and cleaning acids can cause skin irritation. Wash Immediately with soap and clean water. If the skin comes in contact with these.

WARNING

The operating pressure of cooling systems is being progressively increased and some exceed 15 psi. When testing at pressures of more than 15 psi, the push-on rubber caps and plugs may blow off. To prevent this danger, clamps or wires should be used for holding these plugs or caps firmly.

WARNING

Do not under any circumstances mix cleaning compound with antifreeze compound or corrosion inhibitor compound. Never mix the and cleaning compound before putting it into the cooling system. Do not spill compound on skin, clothing, or painted portions of the vehicle. If spilled, flush with clean water immediately.

WARNING

The radiator cap should be turned to the "vent" position before removing, to allow escape of hot steam that might cause personal injury.

Change

No. 2

HEADQUARTERS
DEPARTMENT OF THE ARMY
WASHINGTON, D. C., 3 April 1973

COOLING SYSTEMS: TACTICAL VEHICLES:

TM 750-254, 29 March 1972, is changed as follows:
Page 2-4. Add to Table 2-1 the following entry:

Item	FSN	Reference		Use	Fig No	Item No
		Fig No	Para*			
TESTER, Battery and antifreeze	6630-105-1418		2-29g	Testing coolant protection, degrees Fahrenheit	2-26.1	N/A

Page 2-24. Add the following subparagraph:
2-29g. Use of Battery/Antifreeze Tester (FSN 6630-105-1418). To use this instrument which is available through normal supply channels, place a few drops of coolant on

the clean measuring window, close the cover and sight through the eyepiece. The graph should have a distinct shadow edge across it. See figures 2-26.1 and 2-26.2

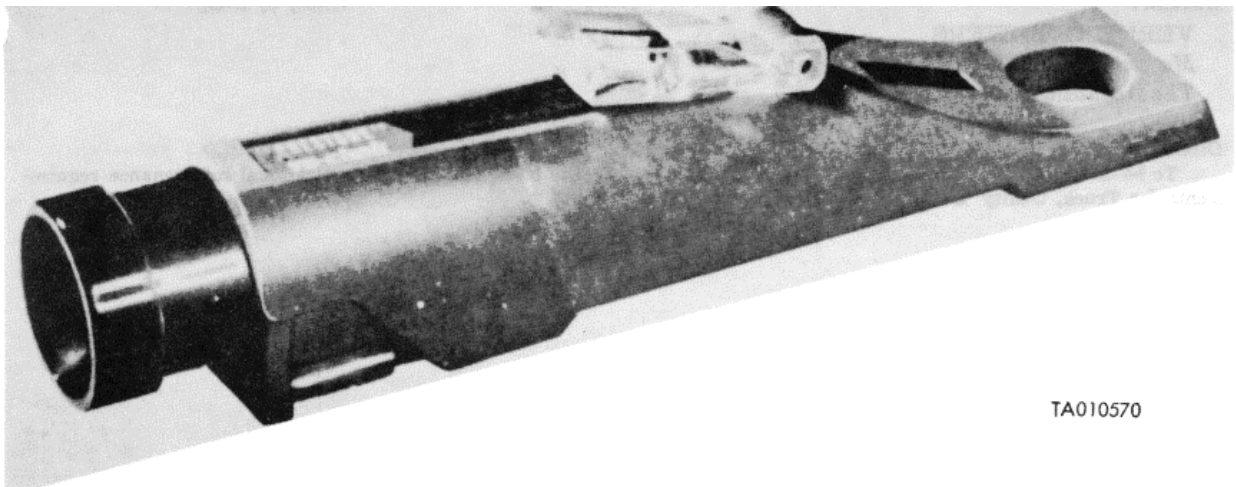

TA010570

Figure 2-26.1. Antifreeze and battery tester

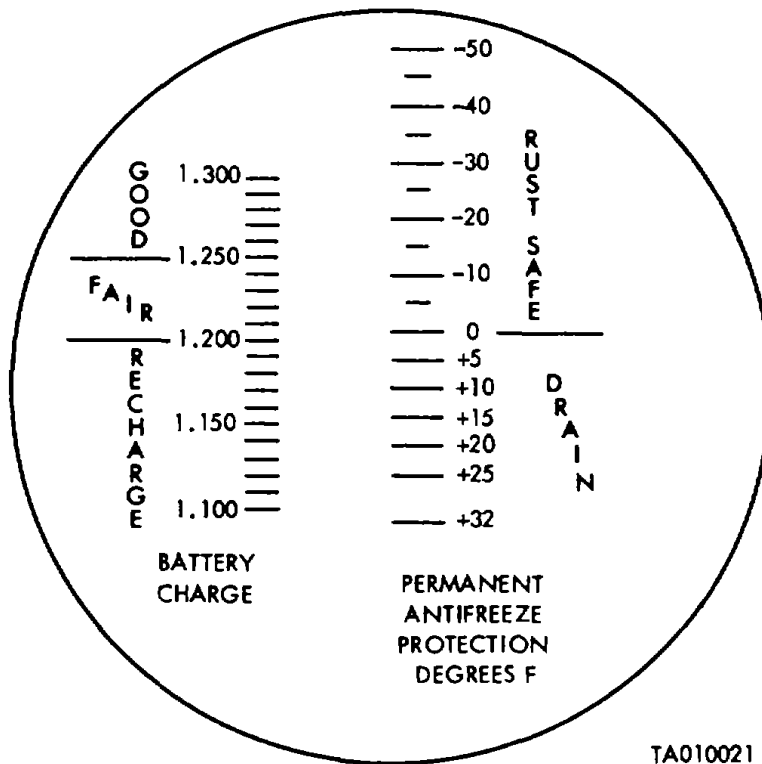

TA010021

Figure 2-26.2. Antifreeze and battery tester scale

By Order of the Secretary of the Army:

Official:

VERNE L. BOWERS
 Major General, United States Army
 The Adjutant General

CREIGHTON W. ABRAMS
 General, United States Army
 Chief of Staff

To be distributed in accordance with DA Form 12-38, (qty rqr block No. 250) Organizational maintenance requirements for Truck, Utility 1/4-Ton, M151.

Change

No. 1

HEADQUARTERS
DEPARTMENT OF THE ARMY
Washington, D.C., 31 October 1972

COOLING SYSTEMS:

TACTICAL VEHICLES

TM 750-254, 29 March 1972, is changed as follows:

Page I. Add the following statement at the top of the page:

"This annual contains copyright material, used by permission of Inland Manufacturing Company."

By Order of the Secretary of the Army:

Official:

VERNE L. BOWERS
Major General, United States Army
The Adjutant General

CREIGHTON W. ABRAMS
General, United States Army
Chief of Staff

Distributions:

To be distributed in accordance with DA Form 12-38 (qty rqr Block No. 250) organizational maintenance requirements for Truck, Utility, 1/4 Ton, M151.

TECHNICAL MANUAL

No. 750-254



HEADQUARTERS,
DEPARTMENT OF THE ARMY
WASHINGTON, D.C., 29 March 1972

COOLING SYSTEMS:

TACTICAL VEHICLES

CHAPTER			Paragraph	Page
	1.	INTRODUCTION		
Section	I.	General.....	1-1	1-1
	II.	Components of cooling system	1-4	1-1
	III.	Inter-relation of cooling system and other engine systems	1-20	1-10
CHAPTER	2.	MAINTENANCE OF COOLING SYSTEM		
Section	I.	Special tools and equipment	2-1	2-1
	II.	Preventive maintenance	2-3	2-4
	III.	Troubleshooting.....	2-23	2-19
	IV.	Coolant	2-25	2-20
CHAPTER	3.	REPAIR OF RADIATOR		
Section	I.	Radiator construction.....	3-1	3-1
	II.	Radiator cleaning.....	3-6	3-3
	III.	Testing.....	3-16	3-6
	IV.	Repair	3-26	3-10
	V.	Repair of aluminum radiators	3-41	3-20
INDEX		ALPHABETICAL INDEX.....		I-1

*This manual supersedes TM 9-2858,8 May 1945 including all changes, and TM 10-4150, SECTION V 21 November 1941

CHAPTER 1 INTRODUCTION

Section I. GENERAL

1-1. Scope

This manual contains maintenance instructions for all levels of maintenance on cooling systems for tactical vehicle engines. Liquid-cooled engines are the primary subject of these instructions.

1-2. Forms and Records

a. Authorized Forms Maintenance forms and records that you are required to use are explained in TM 38-750.

b. Recording. At the completion of the cooling system processing, the condition of the cooling system and the degree of freeze protection shall be recorded on DA Form 2408-1, Equipment Daily or Monthly Log or DA Form 2409.

c. Field Report of Accidents. The reports necessary to comply with the requirements of the Army safety program are prescribed in detail in AR 385-750.

d. Equipment Improvement Recommendations.

Deficiencies detected in the equipment or materials should be reported using the Equipment Improvement Recommendation section of DA Form 2407. For instructions on the use of this form, refer to TM 38-750. Submit the completed DA Form 2407 to Commanding General, U. S Army Tank-Automotive Command, ATTN AMSTA-ME, Warren, MI 48090.

1-3. Reporting of Equipment Publication Improvements

The reporting of errors, omissions, and recommendations for improving this publication by the individual user is encouraged. Reports should be submitted on DA Form 2028 (Recommended Changes to publications) and forwarded direct to Commanding General U S Army Tank-Automotive Command, ATTN AMSTA-MAP, Warren, MI 48090. A reply will be furnished directly to you.

Section II. COMPONENTS OF COOLING SYSTEM

1-4. General

Cooling systems are made up of many individual components. These operate in close association with each other to enable the engine to produce its power efficiently. Reduced performance or failure of any one of these components will require servicing or repairing to restore engine performance to normal requirements. The following illustration (fig 1-1) establishes a nomenclature for these typical components and shows their approximate location in a typical automotive cooling system. In the illustration, the engine block and cylinder heads contain coolant passages which comprise the water jacket.

These passages are designed so that the coolant is distributed in the proper proportions for efficient cooling. Engine block castings have holes in the lower portion of the block. These holes provide openings to the water passages and are necessary for removing the filler and when the block is cast. The holes are sealed by disks which are known as core hole plugs. Plugs offer some protection against block cracking when coolant water freezes. These plugs occasionally leak. Small leaks can be detected by anti-freeze residue and calcium deposits around the plug. Leaky core plugs should always be replaced.

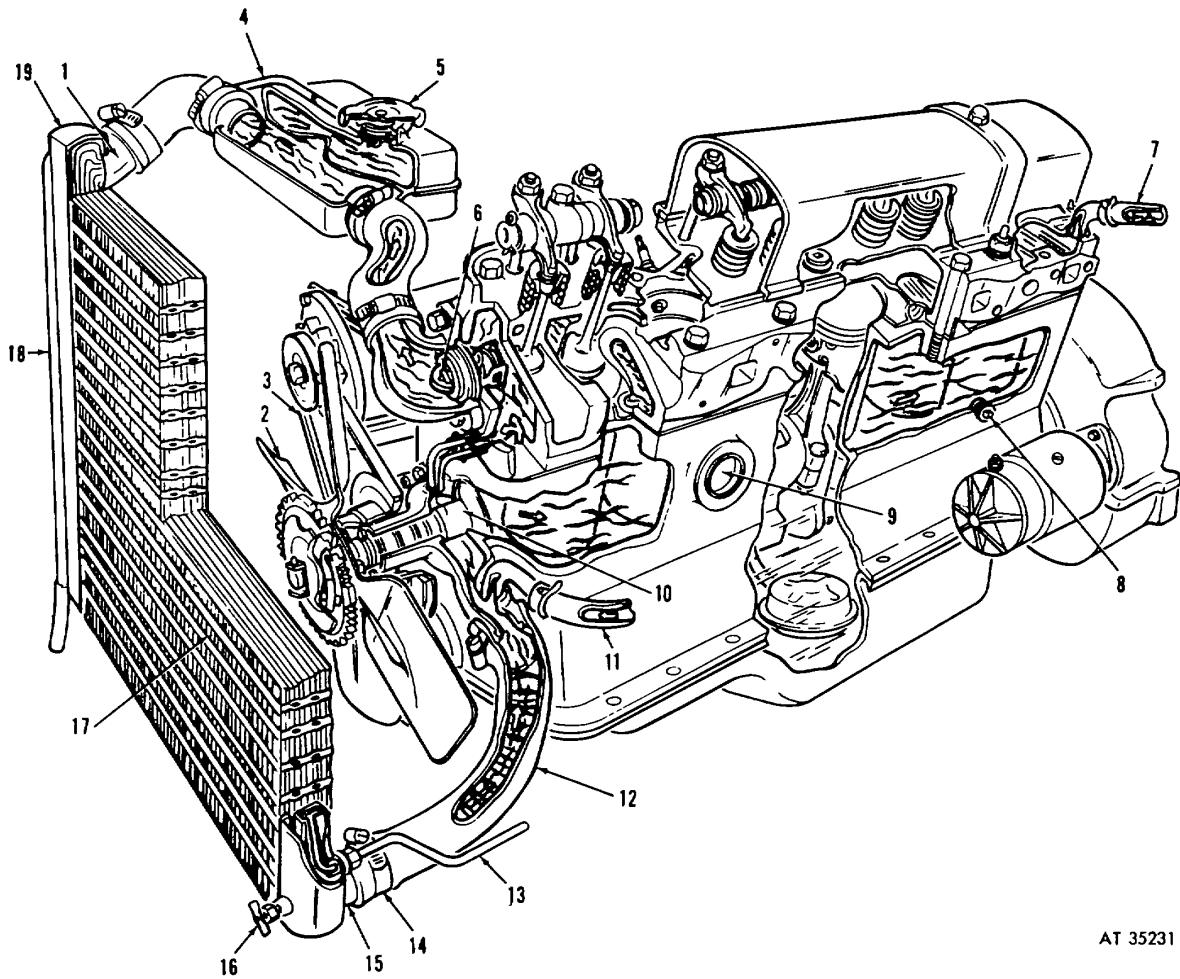

AT 35231

- | | | | |
|----|----------------------------|----|---------------------|
| 1 | Inlet | 11 | Heater line |
| 2 | Fan | 12 | Radiator hoses |
| 3 | Drive belt | 13 | Oil cooler line |
| 4 | Radiator overflow tank | 14 | Hose clamps |
| 5 | Overflow tank pressure cap | 15 | Outlet |
| 6 | Thermostat | 16 | Radiator drain cock |
| 7 | Heater line | 17 | Radiator core |
| 8 | Engine block drain plug | 18 | Overflow tube |
| 9 | Core hole plug | 19 | Radiator tank |
| 10 | Water pump | | |

Figure 1-1. Typical cooling system components

1-5. Drive Belts and Shafts

a. *Belts* (fig 1-2). The most common type of fan and water pump drive makes use of a single belt which is driven by a pulley on the engine crankshaft. Normally, this belt also drives the generator. Other vehicles may have separate belts for one or two of these units, or two belts to drive a single unit. In any case, proper operation of the water pump drive belt is the most critical. When the water pump stops during engine operation, overheating of the engine follows almost immediately. Belts stretch in service, adjustment of belt tension is by movable mountings on one or more units driven by the belt.

b. *Shafts* Some heavy-duty engines make use of a shaft to drive the water pump. Such a shaft is usually driven from the engine crankshaft or camshaft by gears. The shaft often drives the generator as well as the water pump. Flexible couplings are installed in drive shafts to keep them properly lined up in their bearings.

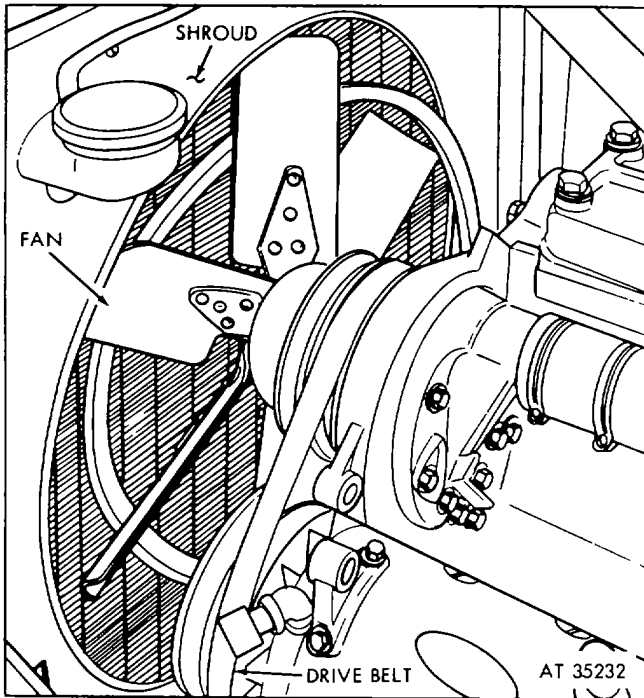

Figure 1-2. Fan, shroud and drive belt.

1-6. Pipes, Hoses and Connections

The purpose of connection hoses and pipes is to isolate the radiator from engine vibrations and to provide a leak proof path for adequate coolant circulation through the cooling system components. Hoses are attached to the various necks and flanges by clamps. Clamps may be snap-on spring wires, screw type adjustable clamps, flange and gasket bolt-on joints or "O" rings. Leaks that are discovered at the hose clamp can often be repaired by tightening when they are of the adjustable screw or bolt flange type.

1-7. Miscellaneous Fittings

a. *Drain Cocks* (fig 1-3) There is always a drain cock or removable screw-type plug located at the bottom tank of the radiator or at the outlet to permit draining of coolant. Similar points of drainage are provided for the engine block. In some systems, there will be a drain cock or plug in the pump housing if it is the lowest point in the system. For complete draining of all parts of the system, every coolant drain plug must be removed and every drain cock opened.

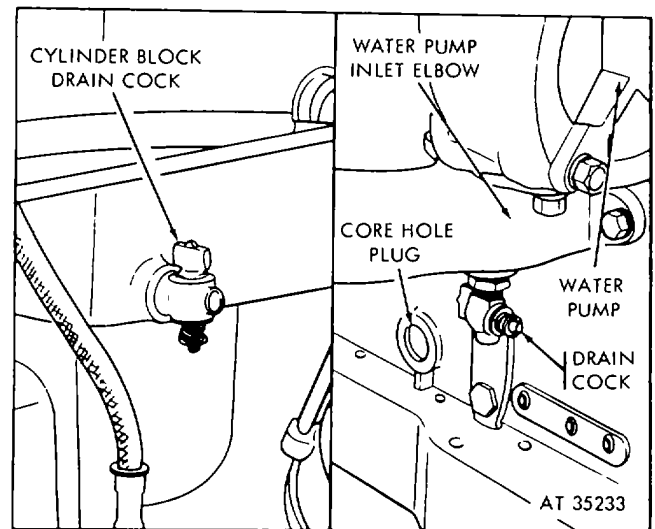

Figure 1-3. Cooling system drain cocks

b. *Steam Escape and Recirculation Tubes.* Some overhead valve engines have a coolant tube connecting the rear end of the cylinder head with top tank of the radiator, which allows escape of steam from the water jacket without causing overflow loss. Coolant flows through this tube into the radiator even with thermostat valve closed, to prevent overcooling of the engine during cold weather, the tube is equipped with a shut-off valve that can be closed. In another design, the tube from the rear of the cylinder head is connected into the thermostat by-pass of that coolant flowing in the tube is recirculated in the water jacket without entering radiator.

c. *Core Hole Plugs* In practically all engine water jackets will be found a number of round openings which are sealed by metal plugs driven into the holes. These openings in the outside walls of the cylinder block or cylinder head are necessary in the casting process, but perform no cooling system function. The core hole plugs which close these openings often incorrectly called "freeze plugs" or "frost plugs". Although core hole plugs may be forced out by a solid freeze-up in the water jacket, they are not a safety device which can be depended on for the prevention of freeze-cracking damage in the engine.

d. *Other Fittings.* In some engines a cover plate or side plate is used to close a large opening on the side of the cylinder block water jacket. One type of cover plate is constructed with passages and outlet holes to provide for distribution of coolant in a manner similar to that of the water distribution tube. A few cooling systems have more than one water outlet from the cylinder head and use an assembly of metal piping called a "water manifold" to carry the coolant to the radiator.

1-8. Fan and Shroud
(Fig 1-2).

a. *Fan.* Operation of the fan pulls a large volume of air through the radiator core. Besides removing heat from the radiator, this flow of air also provides some direct air cooling of the engine. The fan provides most of the air flow through the radiator at low road speeds when the forward motion of the vehicle forces comparatively little air through the core. Reducing the size of the drive pulley increases the speed of the fan. For operation in extremely hot climates, larger fans and smaller pulleys are sometimes installed.

b. *Shroud.* Military vehicles are generally equipped with a tunnel-like structure around and behind the fan called a shroud. The purpose of the shroud is to direct the flow of air for most effective cooling. Some vehicles have air baffles on the front side of the radiator to direct air flow through the core.

1-9. Radiator
(Fig 1-4).

a. *General* The usual radiator assembly consists of a radiator core with a top tank and a bottom tank. In some designs, the tanks may be located on the sides of the cores. The top, or inlet tank contains an outside pipe called the radiator inlet and usually has a coolant baffle inside and above, or at the inlet opening. The radiator filler neck is generally attached to the upper part of the top tank and has an outlet to the overflow pipe. The bottom tank also has opening which is called the radiator outlet. Refer to Chapter 3 for repair of radiator.

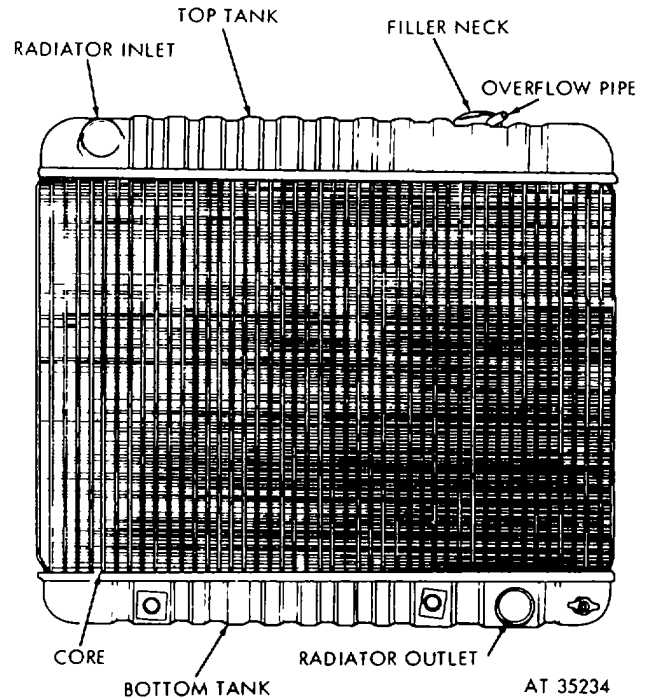

Figure 1-4. Radiator

b. *Function of Tanks.* The top tank collects incoming coolant and distributes it across the top of the radiator core. The baffle in the top tank assists in distributing coolant to water tubes and also prevents coolant from being thrown out of the radiator. The overflow pipe provides an opening from the radiator for escape of coolant or steam that otherwise might cause excessive pressure in the cooling system. The bottom tank collects coolant flowing from the core and discharges it through the radiator outlet.

c. *Core Construction* Practically all military cooling systems have tubular radiator cores which consist of a large number of vertical water tubes and many horizontal air fins around the tubes. Water passages in the tubes are usually very narrow, and the tube itself is made of very thin metal.

d. *Core Function* In the radiator core, a large amount of heat is rapidly transferred from the coolant into the air. Through the water tubes, the flow of coolant is divided into many small streams which causes a small amount of cooling liquid to be exposed to a comparatively large cooling surface in the tubes. This results in rapid flow of heat from the coolant to the tubes and air fins Heat is carried away from the tubes and fins by the air moving through the core

1-10. Radiator Pressure Cap

(Fig 1-5)

a. *General.* The radiator pressure cap contains two spring-loaded normally closed valves. The larger valve is called the pressure valve and the smaller one is called the vacuum valve. A shoulder in the radiator filler neck provides a seat for the bottom of the cap assembly and a gasket on this seat prevents leakage between the cap and the filler neck. By closing off the overflow pipe opening, the pressure cap prevents overflow loss of coolant during normal operation. It also allows a certain amount of pressure to develop within the system which raises the boiling point of the coolant and permits the engine to operate at higher temperatures without coolant overflow from boiling.

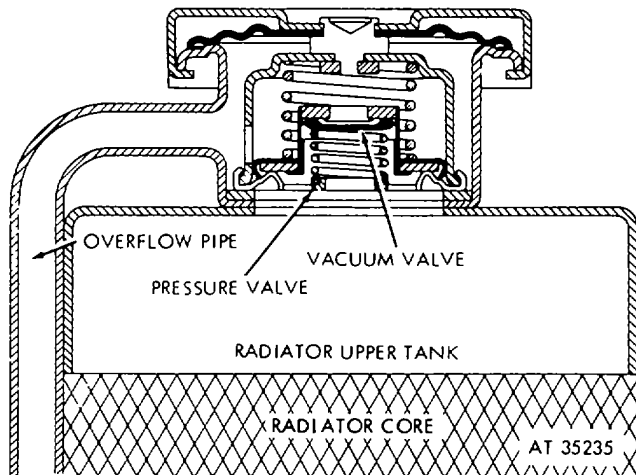

Figure 1-5. Radiator pressure cap - cross-sectional view.

b. Function

(1) *Pressure valve* The pressure valve acts as a safety valve to relieve extra pressure within the system. In the majority of transport vehicles, the pressure valves open at about 4 pounds per square inch. When the valve is forced open, it allows steam and coolant to escape through the overflow pipe until the pressure drops below its opening point. Four pounds pressure in the cooling system will prevent overflow loss from boiling of water until a coolant temperature of about 225°F (at sea level) is reached. Some vehicles have valves with opening pressures as high as 17 pounds This pressure raises the boiling point of water to about 255°F.

(2) *Vacuum-valves* The vacuum valve opens only when pressure within the cooling system drops below outside air pressure as the engine cools down. Higher outside pressure then forces the valves open, which allows air to enter the system by way of the overflow pipe. When pressure inside and outside again becomes approximately the same the vacuum valve closes. This automatic action of the vacuum valve prevents collapse of hose and other thin-walled parts of the cooling system without internal support.

c. Operation of Pressure System

(1) When a system is equipped with a pressure cap it is generally referred to as a pressure-cooling system. The radiator used in such a system is especially designed to withstand extra pressure. Tightness of all connections and joints is particularly important since pressure naturally aggravates any existing leakage. An airtight cooling system is necessary to obtain the benefits of pressure cooling.

(2) Except under the heaviest driving conditions or in extremely hot weather, most military engines can be operated without pressure in the systems. However, in some vehicles normal operating temperature is always above the boiling point of the coolant. Proper functioning of the pressure-cooling system is absolutely necessary to avoid large overflow losses of coolant from boiling, even under average operating conditions.

1-11. Radiator Overflow Tank

(Fig 1-6)

a. *General.* Radiator overflow tanks, sometimes called surge tanks or expansion tanks, are standard equipment for some vehicles. They are installed on other vehicles as special equipment for operation in hot or dry country. The overflow tank serves as a receptacle for coolant overflowing from the radiator and provides for its return to the system. Thus, the overflow tank conserves coolant and reduces the need for frequent filling of the radiator.

b. *Construction.* Overflow tanks may vary in capacity from 2 quarts to a gallon or more. They are usually mounted fairly high with reference to the cooling system. The bottom of the tank is connected to the radiator overflow pipe through a metal tube which is usually connected by short pieces of flexible hose. When the cooling system is equipped with an overflow tank, the pressure cap is placed on the tank rather than on the radiator, and a plain cap is used on the radiator. This cap arrangement leaves the overflow pipe open to the tank. The plain cap on the radiator must always be pressure-tight to permit

the tank to operate properly. Most tanks are equipped with an overflow pipe and drain cock.

c. *Operation.* Either expansion of the coolant when it is heated or steam pressure due to boiling will force coolant into the overflow tank. Boiling may occur during operation, but it happens more often after the engine is stopped. When the engine cools down, pressure in the system drops below the pressure of air outside and any coolant held in the overflow tank is forced back into the radiator. The overflow tank prevents loss of coolant from boiling during periods of severe vehicle operation. However, if the overflow from the radiator is so great that the tank is filled, coolant will be lost through the tank overflow.

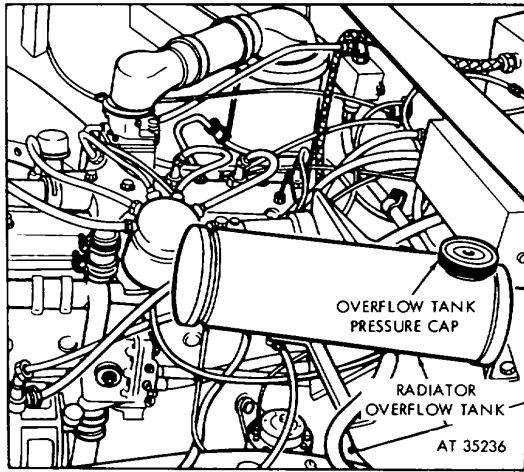

Figure 1-6. Radiator overflow tank.

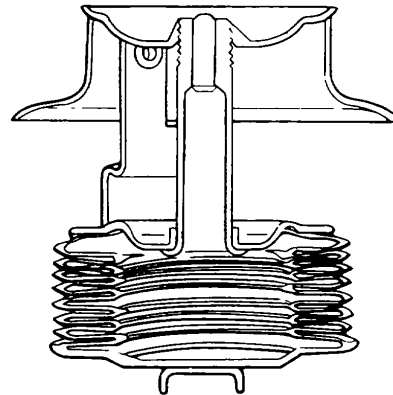
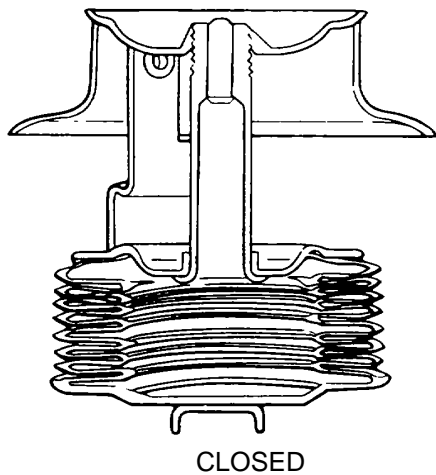

Figure 1-7. Bellows-type thermostat - cutaway view.

1-12. Thermostat

a. *General.* Full-length engine water jackets, large efficient radiator cores, and rapid coolant circulation in the system provide the extra cooling required for engine operation under heavy load in hot weather. However, under lighter engine load in cool weather, the same amount of cooling would remove too much heat from the engine. Therefore, the amount of heat removed from the engine must be controlled for different operating conditions and air temperatures. This is done by the thermostat which regulates engine temperature by automatically controlling the amount of coolant flowing through the radiator core.

b. Construction

(1) *Bellows-type* The thermostat (fig. 1-7) consists of a valve and a heat-operated unit which moves the valve. This type of thermostat-operating unit contains a special liquid designed to boil at a certain temperature. When that temperature is reached, the boiling liquid creates gas pressure which expands the bellows and opens the thermostat valve. When the liquid cools and condenses, pressure is reduced, allowing the bellows to contract and close the valve.

(2) *Coil spring-Type* In this type of thermostat (fig 1-8), the valve is operated by a bimetallic coil which depends for its operation upon the difference of coefficients of expansion of the two metals. The coil expands and opens the valve when heated above a certain temperature. As the coil cools down, it contracts and closes the valve

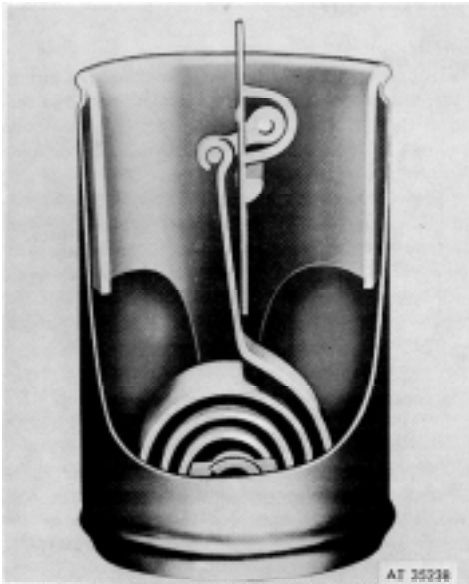
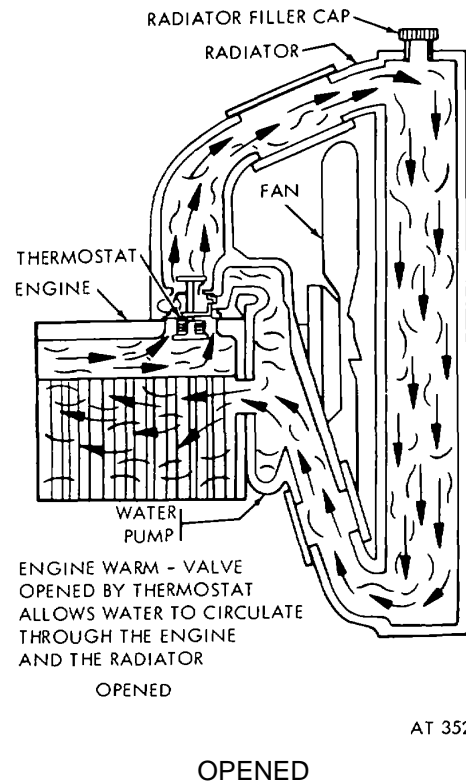
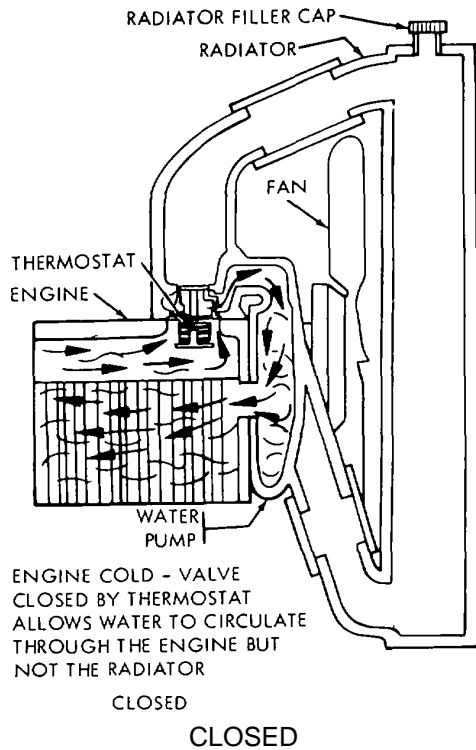

Figure 1-8. Coil spring-type thermostat - cutaway view.

c. *Operation (fig 1-9)* The thermostat is located between the engine water jacket and the radiator, usually in the housing at the cylinder head, water outlet. Automatic operation of the thermostat valve holds coolant temperature within proper limits by controlling flow of coolant through the radiator. When engine is cold, the thermostat valve stays closed and shuts off practically all circulation to the radiator. As the engine warms up, the valve opens slowly, allowing some coolant to flow. In actual operation, the valve may move frequently to regulate coolant flow into the radiator in accordance with variations in heat output from the engine.

d. *Thermostat By-pass.* Cooling systems equipped with a by-pass arrangement have coolant circulation within the engine water jacket when the thermostat is closed. The external-type bypass consists of short hose, pipes, oil tubes connecting the cylinder head outlet directly with inlet of the water pump. The internal-type by-pass provides for coolant flow from the head directly back to the pump through passages built into engine water jacket.



AT 35239

Figure 1-9. Thermostat operation

1-13. Water Pump

a. *General.* Every modern cooling system has a water pump to circulate the coolant in the system. The pump, which is usually located on the front or side of the engine block, receives coolant from the bottom of the radiator and forces it through the water jacket into the radiator top tank.

b. *General Construction* The water pump is a centrifugal-type pump, having an impeller with blades which force the coolant outward as the impeller rotates. The impeller is located in a pump housing and is mounted on a shaft which runs on one or more bearings. The shaft is driven by the engine through a belt or a shaft (para 1-5). The fact that the impeller is submerged in the coolant but must be driven from outside of the cooling system, creates the problem of sealing the impeller shaft against leakage. The water pump shaft seal is the only moving water joint in the cooling system.

c. *Packless Type.* The most commonly used type of pump on military vehicles is the nonadjustable packless type. The packless pump has a built-in, self-adjusting seal. Individual pumps vary somewhat in seal materials and arrangement of assembly. Some packless pumps are prelubricated when assembled, but others require periodic lubrication.

1-14. Cylinder Head Joint

a. *Water Transfer Ports.* The coolant flows from cylinder block up into cylinder head through passages called water transfer ports. The lower part of each passage is in the block, and the upper part is in the head. A tight seal in the joint between the two parts of these water passages is very important.

b. *Cylinder Head Gasket* (fig 1-10) The joints in the numerous water transfer ports, as well as the combustion chamber joints, are all sealed with one large gasket called the cylinder head gasket. To obtain the tightest possible seal in these joints, the openings in the gasket, which match the water transfer ports and combustion chamber openings, are reinforced with metal eyelets described as grommets. The head gasket has a double duty to perform; it must seal the extreme pressures of combustion within the cylinders and at the same time maintain leakproof coolant joints at the water transfer ports. To be specific, the cylinder head gasket must prevent combustion gas leakage to the outside of the engine, between cylinders, and into the water passages, it must also prevent coolant leakage outside the engine, and to the cylinders of the engine. Proper uniform tightness of the cylinder head bolts is necessary to maintain a leakproof head gasket joint.

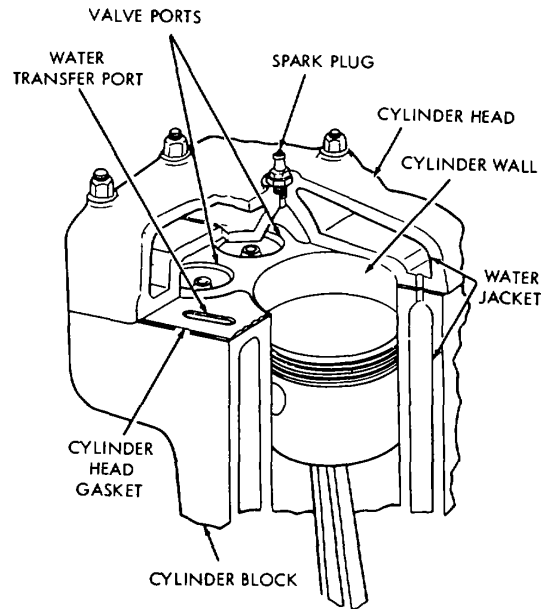

AT 35240

Figure 1-10. Liquid and gas joints in cylinder head gasket.

1-15. Engine Water Jacket

a. *Construction* The water passages in the cylinder block and cylinder head form the engine water jacket. In the cylinder block, the water jacket completely surrounds all cylinders along their full length. Within the jacket, narrow water passages are provided between cylinders for coolant circulation around them. In addition, water passages are provided around the valve seats and other hot parts of the cylinder block. In the cylinder head, the water jacket covers the combustion chambers at the top of the cylinders and contains water passages around the valve seats when the valves are located in the head.

b. *Function and Operation* (fig. 1-11). Passages of the water jacket are designed to control circulation of coolant and provide proper cooling throughout the engine. Waste heat flows directly to the coolant through metal walls of the combustion chambers and cylinders. Heat absorbed by the pistons passes into the coolant by way of the cylinder wall. The heat in the valves flows to the coolant through the valve seats and guides. Since exhaust valves may run as hot as 2,000°F (yellow-red heat), proper cooling around the exhaust valve seat is of special importance.

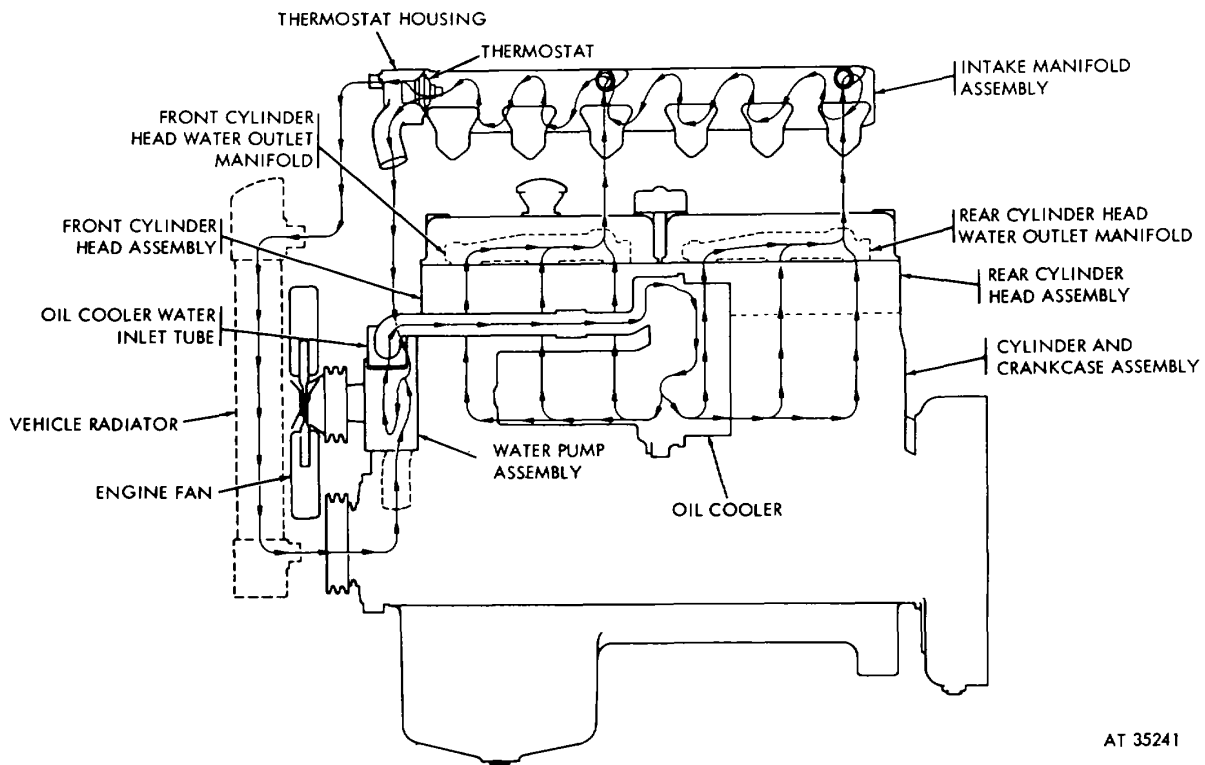

Figure 1-11. Circulation of coolant in engine water jacket.

AT 35241

1-16. Engine Temperature Gage

(Fig 1-12)

a. *General.* The engine temperature gage provides a convenient means for checking engine-operating temperatures. There are two principal parts in the assembly, the gage unit and the temperature sensing unit.

b. *Gage Unit* The gage unit mounted on the instrument panel and connected to the temperature sensing unit registers the temperature of coolant surrounding the engine unit.

c. *Temperature Sensing Unit* The temperature sensing unit is mounted in direct contact with the engine coolant and is usually located at the rear of the engine.

1-17. Water Distribution Tube

a. *General.* Some engines, particularly L-head types, have a water distribution tube in the water jacket extending from the water pump to rear end of engine. This long, flat, thin-walled tube has an opening at one end facing the pump outlet and a number of outlet openings along one side facing the water passages around the exhaust valves.

b. *Function* (fig 1-13) The water distribution tube receives coolant from the pump and delivers it through spaced outlet openings directly to the hottest parts of the engine, such as the exhaust valve seats. The tube is removable, but the water pump must first be taken off before the tube can be reached. In order to draw the tube completely out of the water jacket, the radiator must also be taken out.

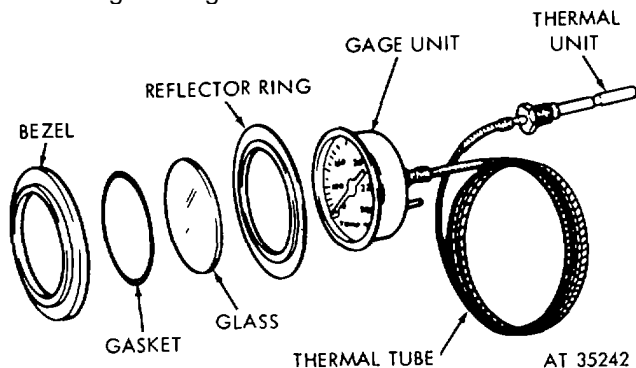

Figure 1-12. Engine temperature gage.

AT 35242

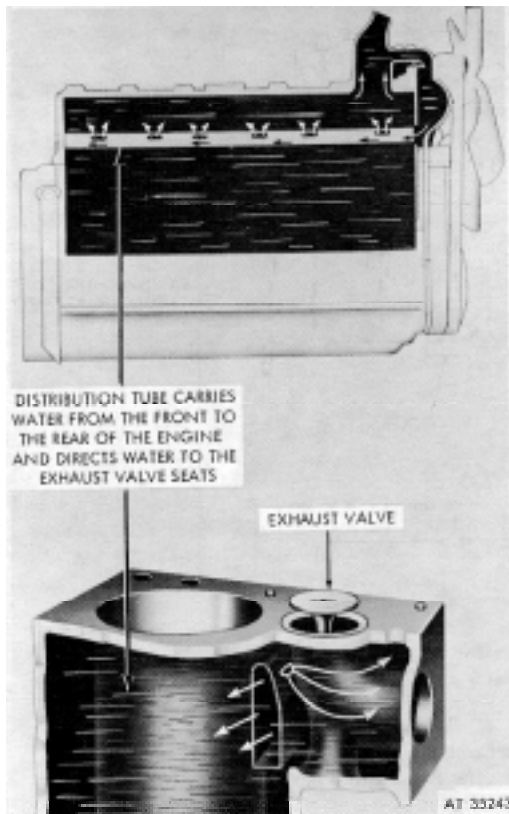

Figure 1-13. Coolant flow through water distribution tube in engine water jacket.

Section III. INTER-RELATION OF COOLING SYSTEM AND OTHER ENGINE SYSTEMS

1-20. General

Separate circulating systems may be connected to the engine cooling system to provide cooling for auxiliary engines and air compressors. In some cases temperature regulation for a chassis unit, such as transmission, is provided by circulating engine coolant through the unit.

1-21. Engine Lubricating System

The cooling system and lubricating system are dependent on each other for proper operation. Flow of lubricating oil assists in keeping the engine at proper operating temperatures by transferring part of the waste heat from pistons to cylinder walls and by removing the heat from bearings. In addition, the oil reduces waste heat from friction by properly lubricating the moving parts. On the other hand, satisfactory lubrication depends on proper

c. Other Coolant Distributing Devices. Some valve-in-head engines have small water nozzles or jets built into the cylinder head to direct the flow of coolant toward exhaust valve seats. Other systems use built-in plates or baffles to direct coolant circulation in the water jacket.

1-18. Shutters, Screens, Etc.

Brush guards, air inlet screens, or similar attachments may have no direct connection with the cooling system and may be entirely for protective purposes; however, they all restrict the flow of air through the radiator and, therefore, must be considered in connection with engine cooling. Improperly adjusted shutters or clogged air inlet screens may reduce air flow so much that cooling capacity of the system can be seriously affected.

1-19. Gaskets

When two flat surfaces are bolted together to confine a liquid under pressure, they are usually sealed with a gasket. In automotive cooling systems, gaskets are used between flanges which house the thermostat. They are also used between water pump flanges and in bolt-on type radiator tanks. See 1-14 Cylinder Head Gasket.

operation of the cooling system. If the coolant fails to remove its share of waste heat, excessive metal temperatures may reduce or destroy the lubricating value of the oil. Excessive heat may also cause chemical changes in the oil which produce sludge, "varnish," and other harmful deposits. Overcooling also interferes with proper lubrication.

1-22. Other Engine Accessory Systems

a. General In a number of ways, the operation of the cooling system affects and is affected by the operation of other engine accessory systems.

b. Fuel System. Overcooling wastes fuel and overheating may cause vapor lock. Conversely, an improper mixture of fuel and air raises the coolant

temperature by increasing the amount of waste heat in the engine which must be carried away by the cooling system.

c. Exhaust System. Since the exhaust system normally removes as much waste heat as the cooling system any obstruction or defect which interferes with the flow of heat from the exhaust system will throw a greater heat load on the cooling system. On the other hand, insufficient cooling can result in excessive wear or other damage to exhaust valves.

d. Electrical System. Improper cooling of combustion chamber walls may result in such high temperatures that spark plugs will be rapidly deteriorated or even damaged. In turn, improper ignition, especially late timing, increases the amount of waste heat thrown into the cooling system and is a common cause of overheating.

1-23. Engine Assembly

a. Adjustments and Clearances The mechanical condition of the engine itself has an important bearing on proper cooling. Valve timing and fit of pistons, piston rings, and bearings may increase or reduce the amount of heat which the cooling system must carry away. Conversely, proper regulation of temperature in these parts is required to prolong their useful life and avoid rapid wear or damage.

b. Engine Performance The regulation of engine operating temperatures by the cooling system is indispensable for dependable performance, maximum power, and economy of operation. None of these are possible without a properly functioning cooling system.

CHAPTER 2

MAINTENANCE OF COOLING SYSTEM

Section I. SPECIAL TOOLS AND EQUIPMENT

2-1. Tools and Equipment

Standard and commonly used tools and equipment having general application to this materiel are authorized for issue by tables of allowances and tables of organization and equipment.

2-2. Special Tools and Equipment

All special tools and equipment are listed for requisition in the pertinent parts manual. Table 2-1 contains only those special tools and equipment necessary to perform the operations described in this technical manual. It is included for information only and is not to be used as a basis for requisitions.

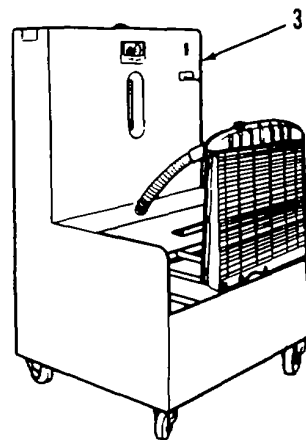
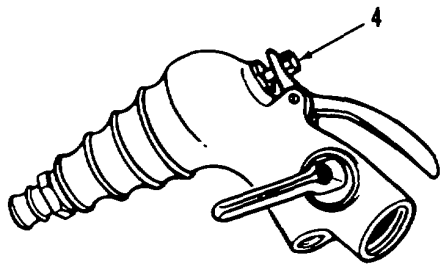
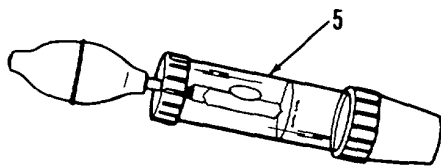
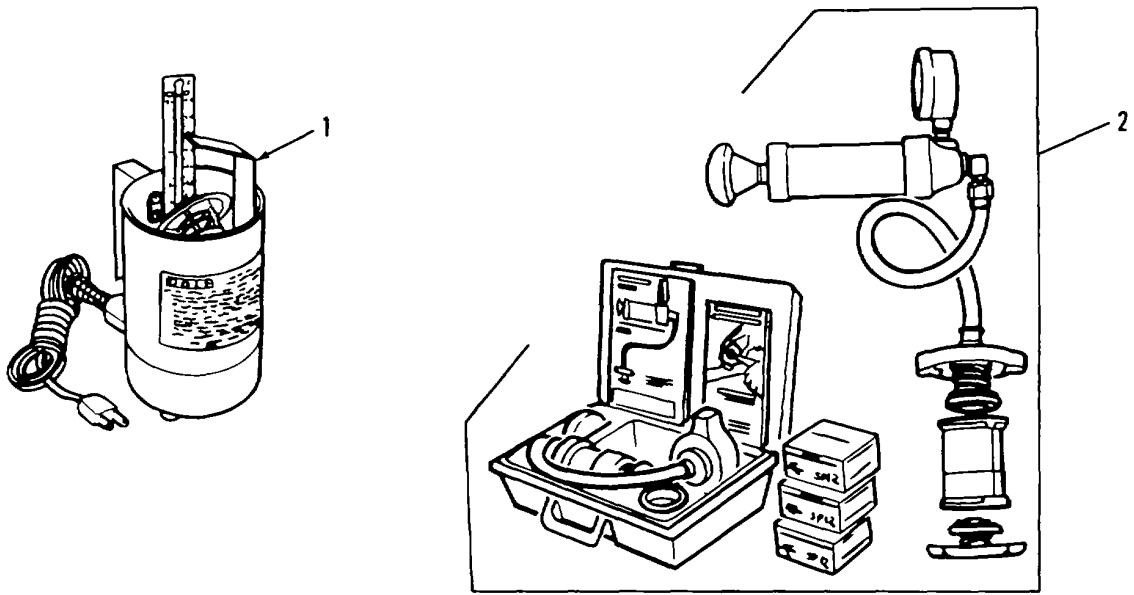

AT 35244

Figure 2-1. Special tools and equipment (sheet 1 of 2)

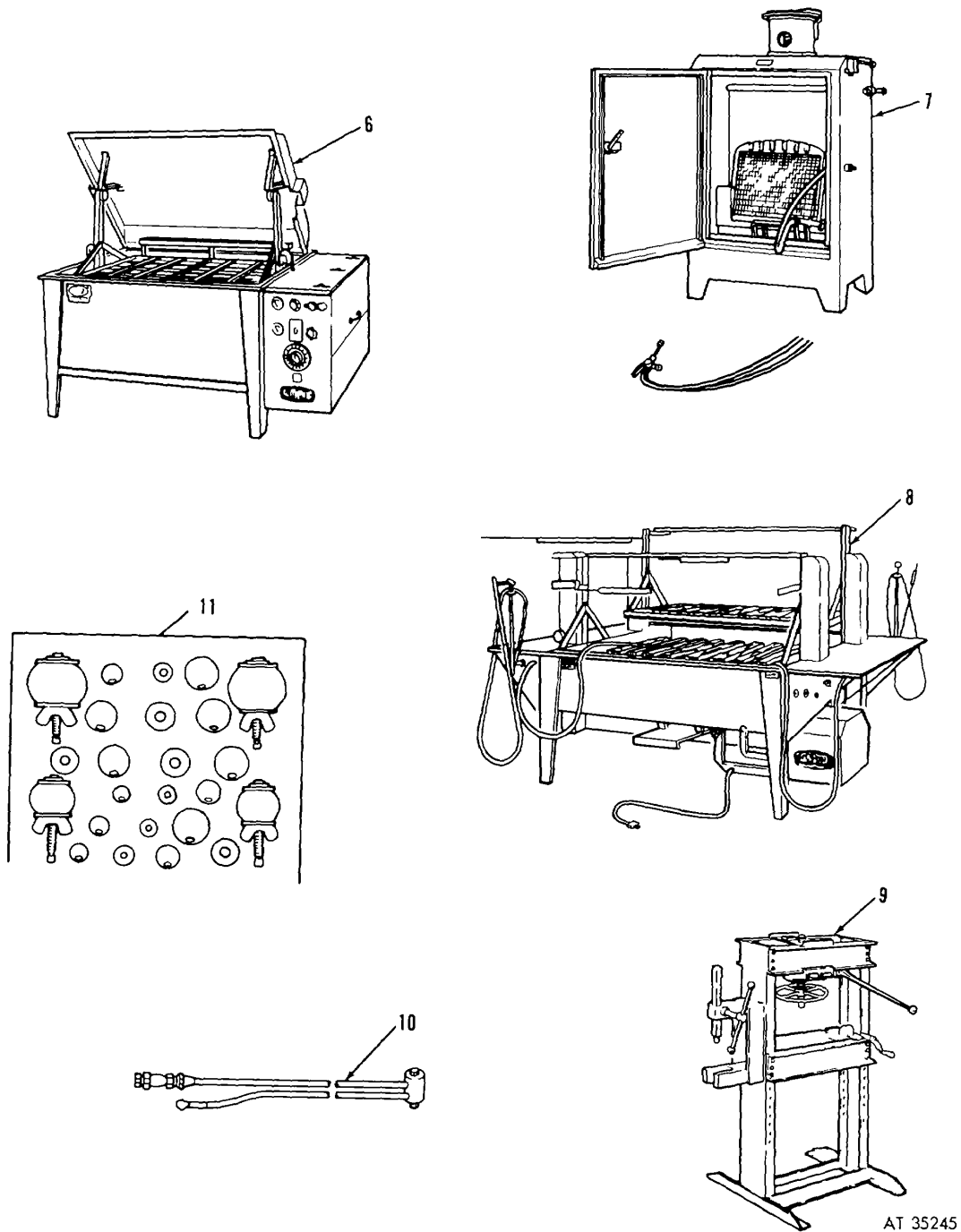

AT 35245

Figure 2-1. Special tools and equipment (sheet 2 of 2)

Table 2-1. Special Tools, Test, and Support, Equipment

Item	FSN or Reference No.	Reference		Use	Fig. No.	Item No.
		Fig No.	Para No.			
TESTER: thermostat			2-7a	Temperature control thermostat and indicator	2-1	1
TESTER: cooling system			2-9d, 3-22	Test radiator caps	2-1	2
TESTER: flo	4910-015-2395		2-17d, 3-18a	Test for radiator blockage	2-1	3
GUN: flushing	4910-449-6790		3-8b	Cleaning radiator and engine block	2-1	4
TESTER: combustion			3-21e	Test for combustion leakage	2-1	5
VAT: cleaning			3-9b	Cleaning radiator	2-1	6
BOOTH: spray	4940-078-4126		3-8a, 3-14	Painting and flushing radiator,	2-1	7
STAND: radiator test	4910-078-9190		3-42e	Radiator testing and repair	2-1	8
PRESS: arbor	3444-449-7295		3-39a	Straightening radiator cores	2-1	9
TOOL cleaning	2815-494-8257		2-22, 2-15a	Removing debris from radiator cooler fins.	2-1	10
SET: plug	4910-273-3660		3-19d	Radiator testing	2-1	11

Section II. PREVENTIVE MAINTENANCE

2-3. General

a. Cooling system preventive maintenance avoids engine-cooling failures, operating difficulties, and loss of equipment use. Neglect of cooling system preventive maintenance services often results in avoidable work, expense, and time required for corrective repairs and replacements. Tools or replacement parts are not always readily available for emergency corrective services, and engine-cooling failures may occur in situations when it is inconvenient or even impossible to perform corrective repair work. However, the most serious penalty for neglecting cooling system preventive maintenance services are operating difficulties, loss of mobility, failure of mission and the serious effect such failure may have on critical military operations,

b. Practically all cooling system troubles can be detected by the driver in their early stages before they seriously affect vehicle operation and they are still easy to correct. For the stationary engine operator or driver the two most important indications are coolant operating temperature and coolant level. Therefore, preventive maintenance services to the cooling system should be concentrated on these two first requirements. While all other preventive maintenance services, such as checks for leakage or defective mechanical condition of parts, are also necessary, these conditions are nearly always indicated by the engine temperature gage, by level of the coolant in the radiator, or by both.

2-4. Engine Cooling Problems in Military Operation

Special requirements of military engines and severe conditions of transport and combat operation make it necessary that the engine cooling system be maintained as closely as possible to maximum efficiency at all times. Many military-vehicles are powered with comparatively large engines which develop proportionately large amounts of heat that must be carried off. Also, cooling is often made more difficult by the presence of air flow obstructions necessary for protection. Weather conditions from the heat of the desert to the bitter cold of the Arctic. Power requirements, which range from emergency high speeds on surfaced roads to heavy uphill hauling through deep mud, add further to the problem of engine cooling. At the same time, military operating conditions, severe shocks, vibration, flying debris, sand and dust. exposure, and accidental and combat damage, cause rapid deterioration of the cooling system and loss of cooling efficiency. To keep the cooling system constantly in repair and in best working order requires the most careful attention to periodic preventive maintenance services by the organizational mechanic.

2-5. Leakage

a. Causes Leakage is probably more common in the vehicle cooling system than in any other liquid-carrying unit, due to the stresses and strains set up in joints and connections by wide changes in coolant and metal temperatures, especially during cold-weather operation. Engine vibration, road

shock, and deterioration of gaskets, and wear, breakage, or corrosion of metal parts may create leakage; these conditions are often more severe in military operation. The radiator pressure cap, which is used on nearly all military vehicles, creates additional pressure in the system, thereby increasing the leakage tendency at hose connections and other water joints. Radiator leakage may be caused by accidental damage to the core from flying stones and debris, minor collisions with other vehicles or objects, or from sabotage and combat damage. Such damage can easily occur without the driver's knowledge.

b. Appearance and Effects Small coolant leaks, which show dampness or even dripping when cold, may not be noticed when the engine is hot, due to rapid evaporation of the leakage. Leakage of antifreeze compound may be easier to find because it evaporates much more slowly than water. Rusty or grayish-white stains at joints in the radiator or engine water jacket (fig 2-2) are usually indications of leakage, even though there appears to be no dampness. Even small leaks should not be neglected, since they often become larger, sometimes suddenly, and generally while the vehicle is being driven. When a driver neglects leakage inspection he risks overheating during operation, possible mechanical breakdown, and failure of his mission.

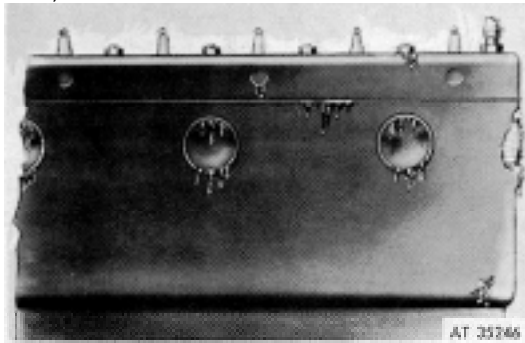

Figure 2-2. Outside leakage of engine water jacket.

2-6. Rubber Hose

Leaks are more common at radiator hose connections than anywhere else in the cooling system. Engine vibration has a tendency to wear and loosen rubber hose connections. Clamps may buckle the hose and threads on the clamp bolt are sometimes stripped. The hose itself has a limited service life. Heat and water cause hose swelling, hardening, cracking, and rotting. Deterioration of

hose usually takes place more rapidly from the inside (fig 2-3) so that outside inspection is not dependable. Hardening of old hose increases the difficulty of keeping connections leakproof. Hose failures not only result in leakage, but may also cause restriction of coolant circulation through clogging or collapsing. Rubber particles from rotted hose linings will clog the radiator water tubes and are very difficult to remove. Rotted hose may break open without warning and cause a large coolant losses. In addition to the usual radiator hose, some military vehicles have other coolant hose and tubes, such as the cylinder head water by-pass and steam relief, and overflow tank tubes. Frequent outside examination of all hose and connections and careful inside inspection of radiator hose whenever the connections are opened, require little time and can save much trouble

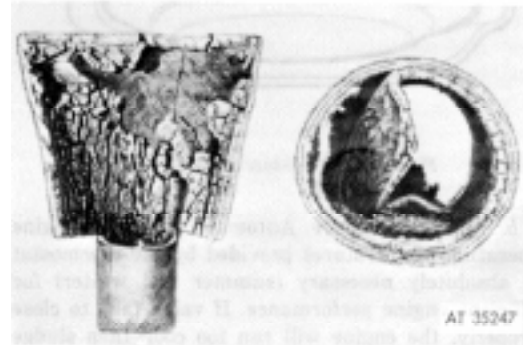

Figure 2-3. Inside deterioration and clogging of rubber hose.

2-7. Thermostat

a. Causes of Failure The function and operation of the thermostat is such that this indispensable unit does not have an indefinite service life and can fail with little or no advance warning. The valve and operating mechanism is subjected to extreme temperature changes, corrosion, and also to wear and bending movement. Rust or foreign matter in the coolant interferes with proper thermostat operation and overheating from any cause may damage it. Defective thermostats may stick open or closed, or they may leak. Thermostat Testers (1, fig 2-1) are available and will prove to be a time-saver. To test, remove the thermostat from the vehicle. Place thermostat in tester, allow to heat and read the thermostat opening temperature.

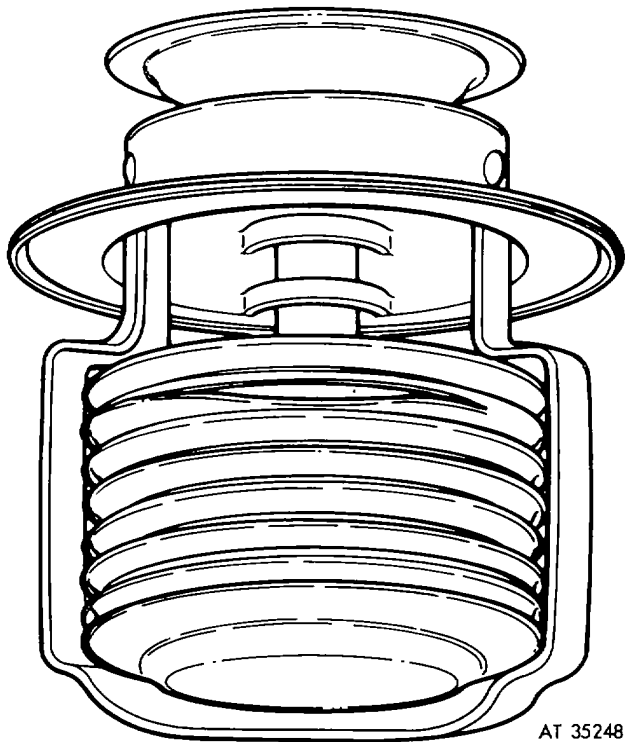

Figure 2-4. Bellows-type thermostat.

b. *Effects of Failure* Automatic control of engine operating temperatures provided by the thermostat is absolutely necessary (summer and winter) for efficient engine performance. If valve fails to close properly, the engine will run too cool; then sludge formation and other harmful effects of overcooling can take place (para 2-18e). If valve fails to open properly, engine temperature will rise and overheating difficulties may follow. Engines should not be operated with thermostat removed, except in case of emergency.

c. *Temperature Gage Check on Thermostat Operation* The temperature gage should be observed during engine warm-up and on road tests in order to be sure thermostat is functioning properly. Whenever gage continually indicates unsafe low or high temperatures, thermostat should be removed and tested.

2-8. Fan and Drive Belts

a. *Fan and Shroud* Military vehicle operation often

requires high engine output at comparatively low vehicle speeds. Under these conditions, the amount of engine heat increases faster than the natural flow of air through radiator resulting from movement of vehicle. Therefore, adequate engine cooling must depend on forced air draft of the fan. Fan efficiency is even more important in stationary engines and in military vehicles having armor, screens, and other restrictions to air flow. Bent fan blades, or a loose, bent, misaligned, or damaged fan shroud interferes with proper air flow and reduces cooling. Periodic inspection and servicing of the fan and shroud assembly is essential to proper engine cooling.

b. *Drive Belts* Preventive maintenance of the fan drive belt is also of first importance, because this belt usually drives both fan, water pump and often the generator. Continuous flexing, friction, and heat cause fan belt cracking, friction, wear, and deterioration. Loose adjustment may result in slippage, rapid belt wear, and an overheated engine. Overtight adjustment also sears the belt and causes early failure of shafts and bearings. In fan, water pump, or generator. A neglected fan belt may break without warning and cause sudden overheating and operating difficulties. Therefore, inspection of fan belt condition and adjustment should never be neglected. Close examination is necessary to discover small flaws, particularly since belts usually begin to crack through from inside. Immediate replacement of doubtful fan belts is good insurance against vehicle failure during operation.

2-9. Radiator Pressure Cap

(Fig 2-5).

a. *Importance of Proper Operation.* The radiator pressure cap has more effect on cooling system operation than is generally realized. A properly operating pressure cap increases the normal margin of safety between coolant operating temperature and boiling point from 5°F to 17°F on transport vehicles and as high as 50°F on some combat vehicles. This additional margin of safety helps to prevent boiling during operation in hot weather, at high altitudes, and under heavy load.

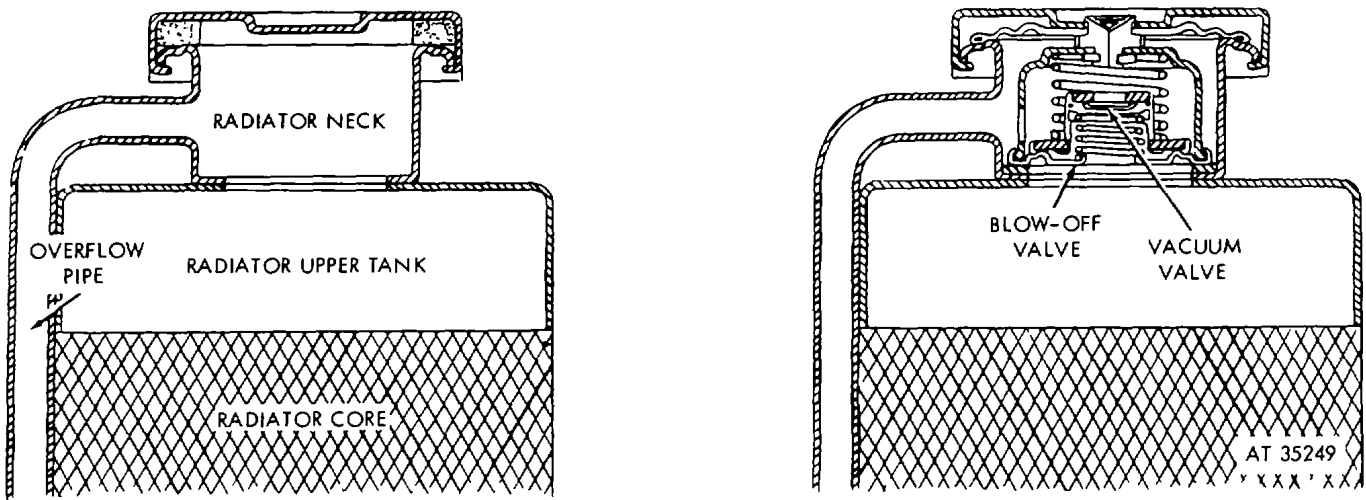

Figure 2-5. Radiator caps, plain - and pressure-type.

b. *Causes of Failure* The radiator cap is subjected to high coolant temperature which cause relatively rapid deterioration of the gasket. The valves and underside of the cap are exposed to extremely corrosive effects of hot steam and air in the upper radiator tank. Since the cap is located above normal liquid level, it receives little protection from rust inhibitors in the coolant (para 2-32), with the result that cap and valves may fall from corrosion damage. Even a small amount of rust scale or dirt will interfere with operation of pressure and vacuum valves. Frequent removal and replacement of radiator cap for coolant level observation increases the possibility of leakage and pressure loss, due to wear of gasket and cap-locking mechanism.

c. *Effects of Failure* An air leak above liquid level in the radiator, such as at cap gasket or pressure valve, will prevent pressure from building up, and benefits of the pressure cap will be lost. Coolant may boil in some cooling systems even at normal operating temperatures if the cap is not pressure-tight. If the pressure valve fails to open, sufficient pressure may build up in the system to break radiator seams or blow off hose connections. Failure of vacuum valve to open when system cools may cause collapse of hose and other parts which have no internal support.

WARNING

The radiator cap should be turned to the "vent" position before removing, to allow escape of hot

steam that might cause personal injury.

d. *Handling and Maintenance* To avoid damage to cap gasket and gasket seat on filler neck, care should be exercised in removing and replacing cap. When filling radiator, metal filling spouts or nozzles should not be allowed to come in contact with filler neck gasket seat. Proper maintenance consists of daily inspection of gap, seat, and gasket, and periodic cleaning of cap and valves, checking of valve operation, and testing for tightness of valves and cap seal (2, fig. 2-1).

2-10. Radiator

a. *Leakage and Failure* (fig 2-6) Engine vibration and road shocks put a strain on all radiator seams and joints that may lead to breakage and leakage, particularly in water tubes, tanks, and outlet and inlet fittings. Additional strain is set up by extreme changes in metal temperatures, especially during cold-weather operation. Cross-country driving over rough terrain multiplies the effects of ordinary shock and vibration. Neglect of small leaks may result in complete radiator failure, excessive leakage, rust clogging, and over-heating difficulties. Thus, it is extremely important to keep the radiator mounting properly adjusted and tight at all times, and to detect and correct promptly even the smallest leaks.

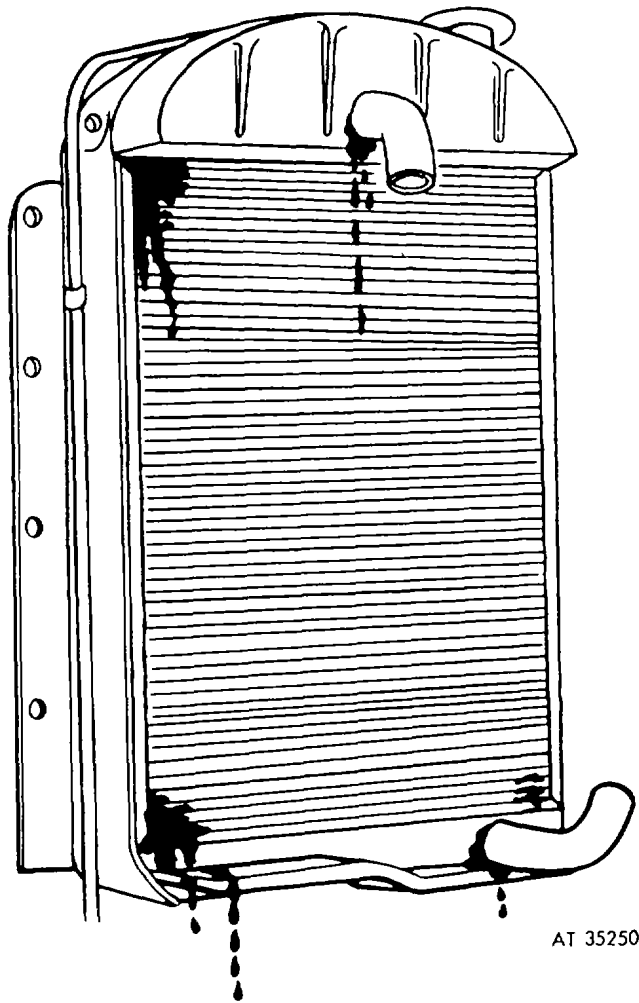

Figure 2-6. Radiator leakage.

b. Air Passage Obstruction. The primary function of the radiator is to transfer heat efficiently from the coolant to the air (para 1-9d). This is not possible without clean, straight air fins and unobstructed air passages. Flying dust, sand, grass, leaves, and other debris may clog air passages in a very short time. Air fins are easily bent and damaged by impact of small stones and from other accidental causes. The problem of maintaining sufficient air flow through the radiator is often further complicated by brush guards, air inlet screens, shutters, armor, etc. Therefore, constant attention to the condition of all air passages and restrictions is required in order to avoid the danger of overheating. In extreme cases, cleaning may be required at least daily.

2-11. Radiator Overflow Tank

a. Function The radiator overflow tank serves as temporary reservoir for coolant overflowing from the radiator while driving, or immediately after the engine is stopped. Any coolant collected in the tank is forced back into the radiator when the engine cools down and creates a vacuum in the cooling system (para 1-9)(fig 1-6).

b. Causes of Failure. Like the radiator cap, the overflow tank is exposed to corrosive effects of steam and air. Being empty most of the time, it receives little protection from rust inhibitors in the coolant. Thin-walled steel overflow tanks may therefore rust through from the inside and allow coolant overflow to leak out and become lost. Water, condensed in the tube connecting pith radiator, may freeze or the tube may become clogged with foreign matter.

c. Effects of Failure. An air leak in tank-to-radiator tube or above liquid level in the radiator can cause failure of the vacuum and prevent coolant in tank from returning to the radiator. In fact, a liquid or air leak anywhere in the cooling system will make overflow tank operation less effective. Clogging of connecting tube not only puts tank out of service but also seals the system, creating the possibility of harmful pressures.

d. Prevention of Failure. Proper functioning of overflow tank depends on maintaining an airtight cooling system, and free unobstructed flow between tank and radiator. This requires frequent inspection for coolant leakage, for air leaks above coolant level, for connecting tube clogging, and for presence of coolant in overflow tank with engine cold.

2-12. Water Pump

a. Pumping Failure The water pump is the only power-driven unit in the coolant system. Pumping failures are most often caused by broken or loose drive belts, but edge wear of impeller blades and wear of pump housing also reduce pumping capacity. Sand, rust, and other abrasive foreign matter in coolant have a tendency to clear areas impeller blades. Corrosion of impeller (fig 2-7) and housing may result from failure to install corrosion inhibitor with water, or to discard rusts antifreeze solution.



Figure 2-7. Corrosion of water pump impeller.

CAUTION

Operation of engine with coolant frozen may shear off the impeller pin and leave impeller loose on shaft, or cause slippage of pump belt drive that would burn belt at the driving pulley.

b. *Leakage (figs 2-8, 2-9)* Leakage is a more common trouble than pumping failure. The pump housing joint is under strain from the pump drive and may cork loose and leak if the mounting bolts are not kept tight. The water pump shaft and seal assembly forms the only moving water joint in the cooling system (para 1-13b). In the adjustable gland-type pump, normal wear of packing will allow leakage unless gland is tightened periodically and packing replaced when worn. Shaft and bearing will be damaged if packing gland is too tight. In newer packless-type pumps (para 1-13d), the self-adjusting seals are subject to wear, deterioration, and leakage. Thrust seal washers and seats are prematurely worn by abrasive action of sand, dirt, and rust in coolant and by operation with engine overheating. Bearing and shaft damage, which leads to leakage and pump failure, can result from neglect of lubrication in pumps that require it. But over-lubrication, especially with a high pressure gun, forces grease into the cooling system, which contributes to clogging and overheating.

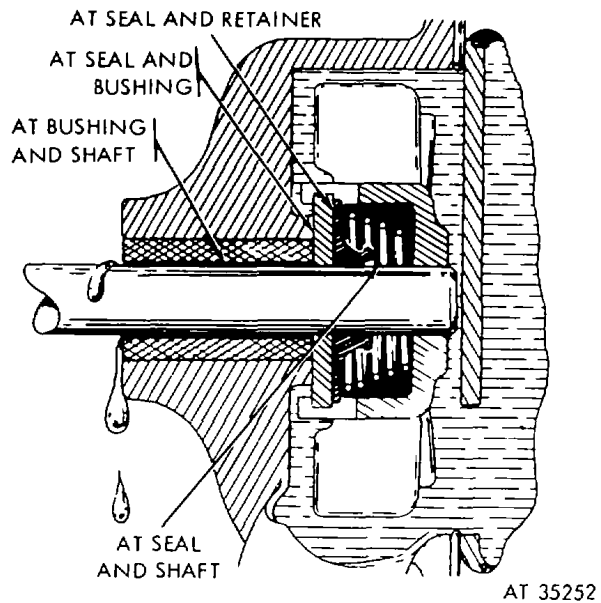

Figure 2-8. Points of leakage in packless-type pump seal.

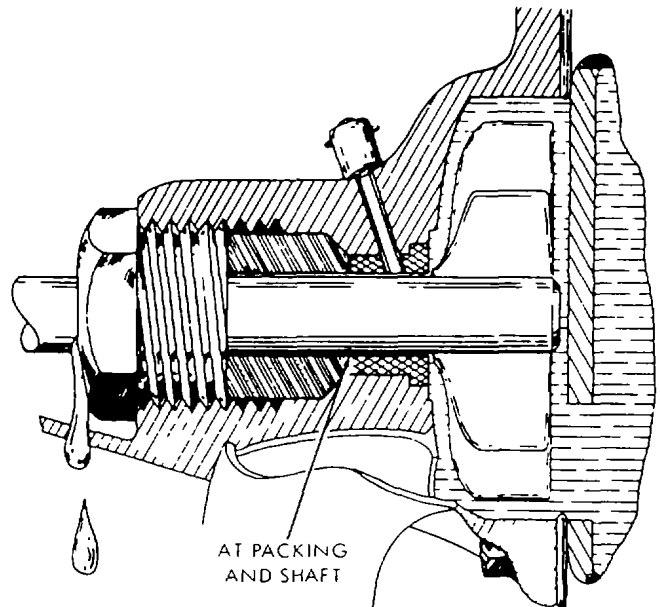

Figure 2-9. Leakage in adjustable gland-type pump seal.

c. *Effects of Failures and Leakage.* Forced coolant circulation is so necessary in the modern cooling system that any reduction in pumping capacity causes a loss of cooling effectiveness. Complete pumping failure is invariably followed by sudden overheating and operating difficulties. Loss of coolant is not the only trouble that can result from a water pump leak. Coolant leakage at the shaft, if not properly corrected, will destroy lubrication and cause corrosion and wear of shaft and bearings. Even

a slight leak at the pump seal or in connections between pump and radiator, will allow air to be sucked into the cooling system at high engine speeds (fig. 2-10). Air suction into the system through a perforated rubber shaft seal can force enough liquid out the overflow pipe to cause serious coolant shortage in a short period of high-speed engine operation. Mixing air with coolant reduces heat transfer and may raise temperature enough to cause overheating at high engine output. Furthermore, introduction of air into the system may speed up rusting as much as 30 times and also greatly increase corrosion of all cooling system metals (para 2-16c). Clogging and corrosion go hand-in-hand with neglected waterpump leakage and air suction.

d. *Preventive Service.* Since results of pumping failure, leakage of coolant, or air suction into the system can be serious, water pumps require careful maintenance in the form of frequent inspection, periodic tightening, and proper lubrication. Prompt detection and correction of leakage is the most important of all water pump preventive maintenance services.

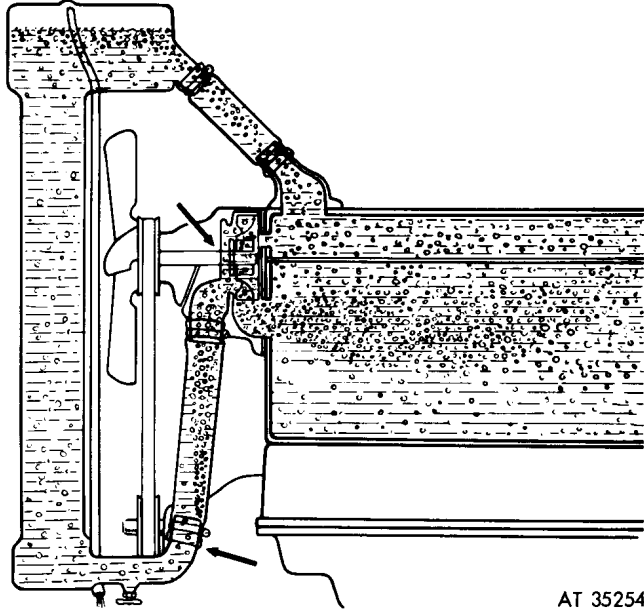

Figure 2-10. Points of air suction into cooling system.

2-13. Cylinder Head Joint

a. *Causes and Effects of Leakage.* The joint between cylinder head and engine block actually consists of a large number of individual water joints at water transfer ports, which are all sealed by one gasket. All of these joints are subjected to the strain of extreme temperature changes within the engine, and also to combustion pressures as high as 600 pounds per square inch or more. Internal leakage at the cylinder head gasket cannot be detected from outside inspection. Leakage of coolant into the engine (fig. 2-11) can cause serious damage, especially in cold weather. Either water or antifreeze solution, when mixed in large quantities with engine oil, will form sludge which may cause lubrication difficulties. If internal coolant leakage is not promptly discovered and corrected, serious engine damage can result. Even though the joint is tight enough to prevent liquid leakage, the slightest amount of looseness will allow combustion gases to be blown into the cooling system (fig. 2-12). This can force coolant out the overflow pipe. Burned gases dissolve in coolant to form acids which cause rapid rust formation and attack metal parts.

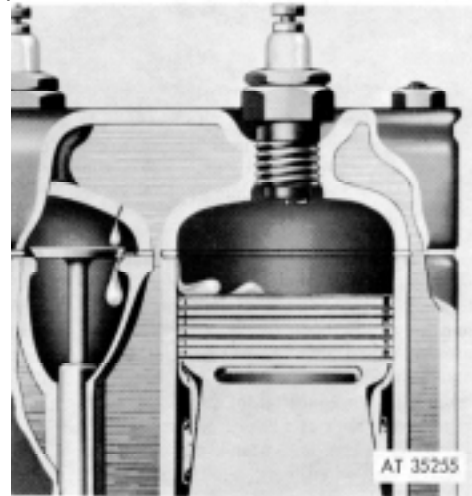

Figure 2-11. Coolant leakage into engine.

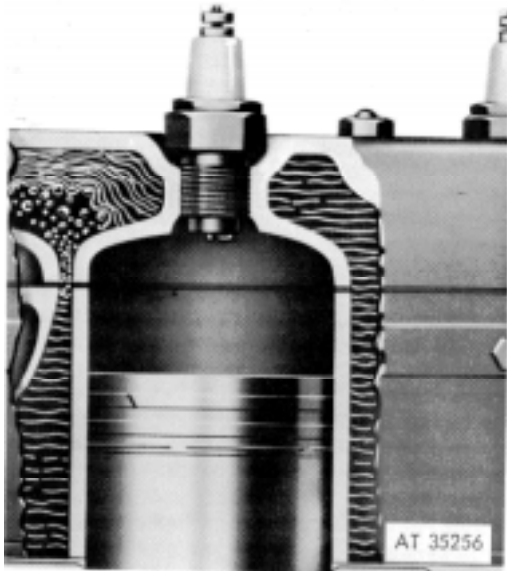

Figure 2-12. Exhaust gas leakage into cooling system.

b. *Prevention of Leakage.* Considering the many possible points of leakage at the cylinder head joint and the seriousness of coolant leakage into the engine, it is imperative that the cylinder head always be kept perfectly leakproof. Cylinder head bolts cannot be evenly tightened with an ordinary wrench. Use of a torque-indicating wrench is necessary to obtain proper uniform pressure on all bolts and to avoid warpage of head or distortion of block at valve seats and cylinder bores from overtightening. The extreme importance of maintaining cylinder head joint tightness demands careful attention to all instructions on installation of new gaskets, proper order for tightening bolts, correct torque to apply, and rechecking torque following a new gasket installation. If any stud bolts are loosened in the block when removing cylinder head, they should be tightened before head is installed.

2-14. Engine Water Jacket

The engine water jacket has many gasketed water joints and a number of metal water joints in both block and head, where preventive maintenance neglect may result in leakage. Vibration, pressure, and wide changes in engine temperature, impose strains on all these points. Gaskets deteriorate from effects of heat, water, and pressure. Gasket joints at thermostat housing and water pump mounting are common points of leakage. Metal joints, such as core hole plugs, drain plugs, shut-off valves, temperature gage fittings, and connections at water bypass or recirculation tubes, are all subject to leakage. Corrosion leakage occasionally develops in metal water joints. Any leakage at water jacket joints or casting cracks is aggravated by pump pressures which may run as high

as 35 pounds per square inch (fig. 2-2). Pump pressures are naturally greater at higher engine speeds and while the thermostat is closed. The radiator pressure cap also allows additional pressure to build up when the coolant is boiling.

2-15. Accessories Connected to Cooling System

a. *Description.* Many military vehicles have one or more independent circulating systems connected by hose or tubing to the engine cooling system for the purpose of heating or cooling of oil coolers, air compressors, transmissions, etc. The water pump circulates coolant to radiators and water jackets of these accessories in the same manner as to the vehicle radiator and engine water jacket.

b. *Effects of Leakage and Clogging.* Leakage in these units may affect cooling in the entire system either through coolant shortage or by excessive coolant contamination, such as oil from the engine oil cooler. The unit itself may be damaged by leakage, as in the case of coolant leakage into a transmission. Restriction of coolant flow in the connecting hose and tubes may also seriously interfere with proper operation of such units.

c. *Preventive Maintenance.* Cooling system preventive maintenance includes inspection of all special circulating systems to see that they are secure, leakproof, and in good condition.

2-16. Cooling System Corrosion

a. *Rust Formation.* A chemical combination of iron, water, and air produces rust. The water jacket of the automotive engine has a large mass of iron exposed to the cooling water, and no cooling system is free of air. Thus all elements of rust formation are found in the cooling system. Rust is a product of a chemical process called corrosion. Over 90 percent of the solid matter that clogs radiators is rust. Corrosion not only produces harmful products like rust, but also damages iron and other cooling system metals. When two different metals, such as iron and copper, are placed in contact with each other and then immersed in water, a corrosive action called electrolysis takes place and electric currents flow through the water from one metal to the other in exactly the same manner that electricity is produced in a battery. Although these currents are very weak, over a period of time they cause localized corrosion that weakens, pits, and sometimes eats completely

through the metal. Electrolytic corrosion in the cooling system can result from a combination of different metals in contact with each other, such as soldered seams in copper or brass radiators, brazed joints in steel tubes, copper gaskets in contact with iron, and imperfect plating on thin steel parts.

b. Contributing Causes. The rate of rust formation and corrosion within the cooling system is influenced by many conditions of service and operation.

(1) *Air in the coolant* (fig. 2-13). Aeration (mixing air with water) can increase corrosion of iron as much as 30 times. The normal source of aeration in the cooling system is the radiator top tank. At higher engine speeds, the rush of coolant into the radiator is great enough to drive air into the liquid and carry air bubbles down through the water tubes (para 2-20b.). If coolant level is allowed to drop as low as the top of the water tubes, suction of the water pump will draw air in through the overflow pipe and down through the water tubes.

(2) *Temperature.* Heat speeds up corrosion, and unfortunately the rate of corrosion with iron appears greatest at coolant temperatures corresponding to best engine performance. Iron, solder, and copper will corrode more than twice as fast at 175°F than at 70°F.

(3) *Impurities in water.* Some natural waters are less corrosive to iron than distilled or rain water, but others, which contain dissolved mineral salt impurities, are particularly harmful to cooling system metals. Any acid condition in natural waters will increase iron corrosion and rust formation. Hard water containing large amounts of lime and certain other minerals will deposit scale at "hot spots" in the engine water jacket, if large quantities of the water are added to the cooling system over a period of time.

(4) *Contamination of coolant.* Coolant may become contaminated as a result of extended service (para 2-32f), a faulty condition within the system, or for improper maintenance. Excessive aeration from a neglected suction leak at the water pump (para 2-13b) (fig. 2-10) or at any point between pump and radiator, speeds up corrosion and shortens the rust-free life of the coolant. Combustion gas dissolved in coolant from a leak at cylinder heat joint has a similar effect to aeration (para 2-14a.) (fig. 2-12). Corrosive contamination of coolant can also result from failure to neutralize and flush out cleaning solution (para 2-21b).

c. Effects of Rust Formation.

(1) *Water jacket deposits.* If rust deposits are allowed to build up in water passages of the block or head (fig. 2-14), they may hold enough heat in the metal to create local "hot spots", especially around the valve seats. Steam pressure from local boiling at such hot spots is a hidden, although common cause of overflow loss. The metal may get so hot as to cause sticking, warping, or burned valves (fig. 2-15), or even a cracked block or head.

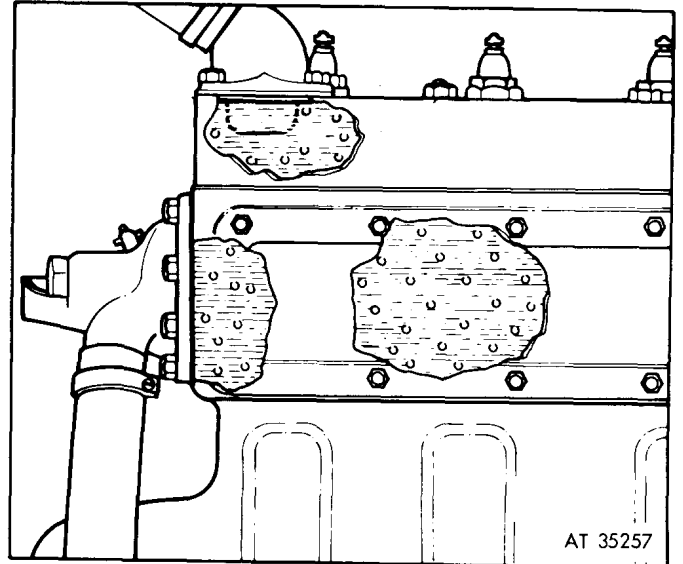

Figure 2-13. Engine water jacket showing air mixed with coolant.

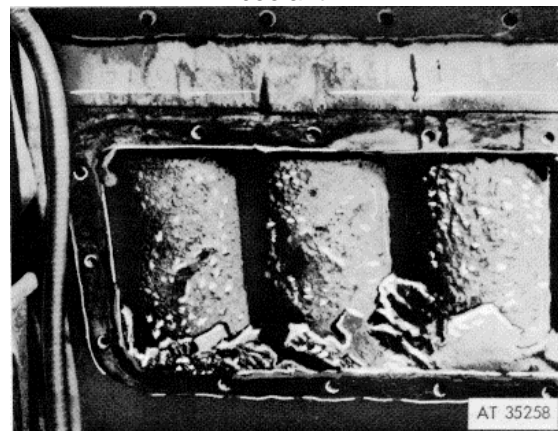

Figure 2-14. Rust deposits in engine water jacket.

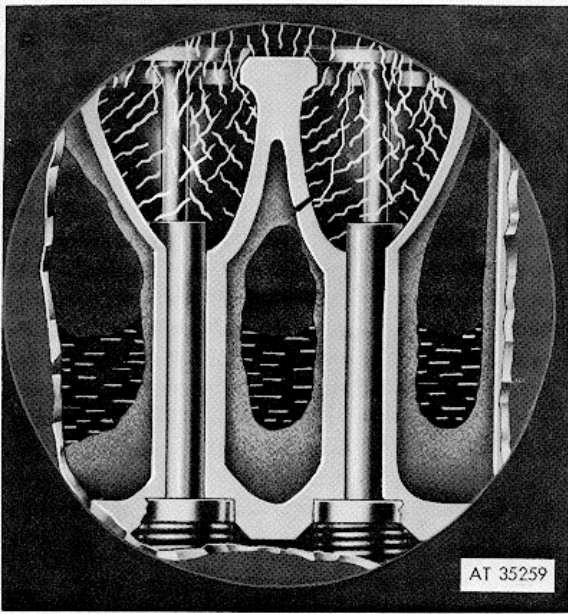

Figure 2-15. Heat cracking at valve seat from rust clogging.

(2) *Radiator clogging.* Rust deposits have their most harmful effects in the radiator. Even a small amount of fine rust particles continually circulating through the radiator has a tendency to plate out in the form of a thin, hard scale on the inside of the narrow water tubes (fig. 2-16). This scale first reduces cooling efficiency of the radiator by insulating tubes from coolant. As more rust becomes lodged in tubes, circulation is restricted and clogging may progress to the point where coolant will be forced out the overflow pipe. When boiling starts, large amounts of rust are stirred up in the water jacket and carried over into the radiator to completely plug tubes. Further operation of the vehicle will result in serious overheating, loss of power, and engine damage.

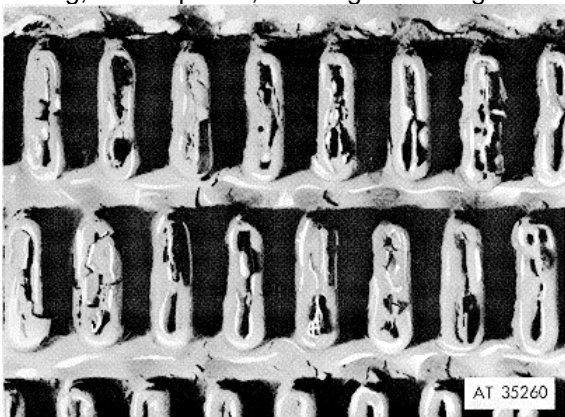

Figure 2-16. Rust clogging of water passages in tubular radiator core.

d. *Corrosion Damage* Although a less common cause of trouble than rust clogging, corrosion damage to metal parts can be equally serious. For example, when a water distribution tube in the block becomes perforated by corrosion (fig 2-17), coolant distribution in the water jacket is completely upset. Some valve and cylinders will be robbed of proper circulation and cooling, and hot spots, overheating sticking valves, and even heat-cracking may follow. Corrosion prevention is especially important for such parts which are so completely hidden within the engine that preventive inspection is impractical and detection of failure is difficult. Among other metal parts sometimes damaged by corrosion are radiators, water pumps, cylinder heads (figs 2-17, 2-18) and core hole plugs. Thin metal parts are weakened by corrosion and crack more easily when subjected to vibration and strain.



Figure 2-17. Corroded water distributor tube showing irregular corrosion holes.

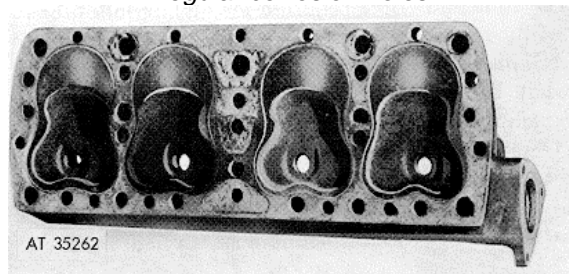

Figure 2-18. Aluminum cylinder head showing corrosion damage.

e. *Importance of Rust Prevention.* A rusty cooling system may seem to function satisfactorily under moderate operating conditions, but will fall to cool the engine under more severe conditions, often at the time when full power output is most urgently needed. The system can be kept practically rust-free, and loss of cooling efficiency from rust formation can be avoided by periodic corrosion-prevention services.

2-17. Prevention of Rust and Corrosion

a. *Inhibitors.* Protection of the cooling system against rust and corrosion is accomplished by adding inhibitor to the coolant (para 2-32). Laboratory tests show that a corrosion inhibitor in water reduces the normal rusting of iron at least 95 percent.

b. *Inhibitor in Antifreeze* Since inhibitors are included in antifreeze compounds (para 2-32c), no inhibitors of any kind should be added to fresh antifreeze solutions. However, corrosion inhibitors may be weakened by use in the cooling system. Therefore, it is important to add an inhibitor to reclaimed antifreeze solutions that are to be used a second winter (para 2-32g).

CAUTION

Do not add any more or any less Inhibitor than specified in current directives.

c. *Inhibitor for Water.* Corrosion protection is particularly important during warm-weather driving when water is used as coolant, since there is more air in the coolant and more rusting in the system. In very cold weather, control of coolant circulation by the thermostat may reduce flow into the radiator to only a few gallons per minute and very little air is driven into the coolant. In hot weather, with thermostat wide open, the flow into the radiator at high engine speeds may increase to 100 gallons a minute or more in some engines. The resulting increase in coolant aeration, together with a higher metal and coolant temperature, greatly speeds up the rate of rusting (para 2-16b). Installation of inhibitor with water coolant is a most essential preventive maintenance service.

d. *Rust Prevention vs Cleaning or Replacement.* The time and effort required for adding inhibitor to a filling of fresh water or for adding reinhibitor to reclaimed antifreeze solution is only a fraction of what is necessary for cleaning a rusty system in which corrosion-prevention services have been neglected, or for replacing a clogged or corroded radiator. However, if restriction of flow of inhibitor is suspected, then flo-tester (3, fig. 2-1) should be utilized to determine amount of restriction.

2-18. Coolant Operating Temperature

a. *General.* Frequent observation of the engine temperature gage during operation is a primary preventive maintenance service for detecting overheating or overcooling of the engine in the first stages, before serious trouble develops.

b. *Overheating difficulties.* Excessively high engine temperatures not only cause "knock" and loss of power, but also will result in damage to bearings and other moving parts. Cylinder heads and engine blocks are often warped and cracked by terrific strains set up in the overheated metal, especially when coolant is added immediately afterward without allowing the engine to cool. Overheating first causes coolant boiling. If the vehicle is operated with boiling coolant, steam pressure forces large quantities of coolant out of the system through the radiator overflow pipe. More violent boiling then occurs, and still more

coolant is lost. Finally, coolant circulation stops, and cooling falls completely. This means that operating an engine with the coolant boiling for even a short length of time may be actually driving that engine to destruction.

c. *Overcooling Difficulties.* Although less sudden in effect than overheating, overcooling may be equally dangerous to the engine. Low engine operating temperature, especially during freezing weather, results in excessive fuel consumption, dilution of engine oil by unburned fuel, and formation of sludge from condensation of water in cylinders and crankcase. Lubrication failure may follow sludge formation and lead to serious engine damage. Burned fuel vapors also mix with water in the crank case and form corrosive acids which attack engine parts.

d. Temperature Gage Observation

(1) To avoid overheating difficulties, the operator must be constantly alert to see that the temperature gage does not exceed the maximum safe operating temperature specified for the vehicle. Whenever the gage registers above this temperature, the vehicle should be halted, the engine stopped, and the cause investigated and corrected before further operation is attempted. It is also important to watch the gage for a sudden rise in temperature during engine warm-up as an indication of defective cooling.

(2) To prevent overcooling difficulties, keep any necessary warm-up period before operation as short as possible, and avoid continued operation of the vehicle if the temperature gage does not reach the minimum operating temperature specified for the vehicle.

(3) When checking for either overheating or overcooling, the possibility of a false temperature indication from a defective gage should not be overlooked.

(4) Prevention of both overheating and over cooling difficulties thus requires temperature gage observations both before and during operation. It also requires a positive knowledge by the driver or engine operator, of the highest and lowest safe operating temperature specified for the particular engine.

2-19. Coolant Examination

Another most important cooling system preventive maintenance service is examination of the coolant for color and cleanliness, at least weekly. This can be conveniently done during coolant level inspection by drawing a sample into a suitable hydrometer or antifreeze tester. In a system that was reasonably clean when the coolant was originally installed, the appearance of rust in the radiator or in the coolant.

is an indication that the corrosion inhibitor has lost its effectiveness. Rusty cooling water or antifreeze solution should be drained, discarded, and replaced at the first opportunity. Rust in the radiator, rusty coolant, or coolant containing oil or other foreign matter also indicates the need for preventive cleaning of the system.

2-20. Coolant Level

a. *Coolant Level Checking.* The level of coolant in the radiator is the starting point for proper cooling system preventive maintenance. Coolant level should be checked accurately as well as frequently for three separate purposes: (1) to make sure the system always contains enough coolant, (2) as a guide to cooling system condition; and (3) to avoid overfilling.

b. *Coolant Shortage.* It is important to make sure that the system contains a sufficient quantity of coolant at all times, if the most common cause of overheating is to be avoided. Low coolant level may prevent proper circulation, especially at lower engine speeds. At higher engine speeds, low coolant level allows a large volume of air to become mixed with the liquid. Air bubbles in the coolant not only reduce the capacity of the coolant to carry away heat, but also promote rapid rust formation and corrosion, and may cause excessive foaming and coolant loss out the overflow pipe. In any case, coolant shortage leads to overheating, operating difficulties, and engine damage (para 2-18b). Having sufficient coolant in the system at all times is especially important in military operations, due to the necessity of being constantly prepared for all possible operating emergencies.

c. *Coolant Level as Indicator of Cooling System Condition.* The second reason for checking coolant level is less generally understood. In the military vehicle cooling system equipped with a radiator pressure cap, very little coolant should be lost through evaporation or from any other cause if the system is clean, leakproof, and in proper working order. Therefore, any unusual coolant loss over a period of normal operation may indicate an improper condition within the system, any such condition should be located and corrected before it causes serious trouble.

d. *Standard Coolant Level Maintenance* The operator can assist greatly in the early detection of irregular conditions inside the cooling system by keeping track of the quantities of coolant necessary to maintain the standard height of liquid level in the radiator as specified for his equipment. The coolant level should always be checked at approximately the minimum safe operating temperature, if possible, since the level rises as the engine warms up and falls as the engine cools down (para 2-27).

Any unusual increase in the amount of coolant needed to bring the level up to standard height should be investigated. It should be corrected by the operator or reported by him as a possible indication of trouble developing in the system.

e. *Overfilling* (fig 2-19) If the radiator is continually filled above specified level or when the engine is not up to minimum safe operating temperature, any changes in the level or the quantity of coolant additions will be of little value as an indicator of cooling system condition. Both water and antifreeze expand when heated (para 2-27), and if there is not enough air space left in the radiator for this expansion, some coolant will be lost through overflow. Overfilling the radiator while using water results in dilution and weakening of corrosion inhibitor solution (para 2-32). Unnecessary additions of water increase water scale deposits which interfere with removal of heat from the engine. Overfilling also wastes antifreeze and when a system containing antifreeze is overfilled with water, it may lead to a freeze-up.

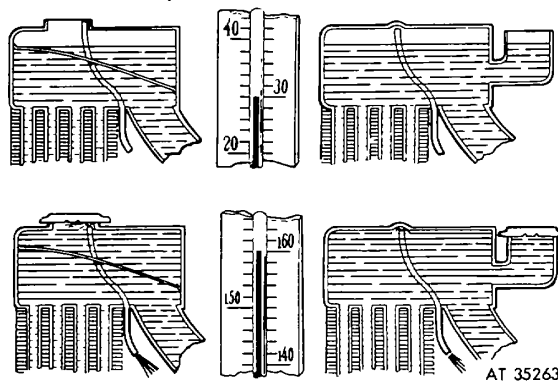

Figure 2-19. Loss of coolant through expansion by heat when radiator is overfilled.

f. *Operator's Responsibility.* Coolant level preventive maintenance services by the operator consist not only of keeping sufficient coolant in the system at all times without overfilling, but also include maintaining a standard level at a specified temperature to provide a sensitive indication of any hidden trouble that might develop in the system.

2-21. Preventive Cleaning

a. *General* The cooling system should always be cleaned following the draining of rusty or contaminated coolant before fresh coolant is installed. Neglect of cleaning at this time may result in overheating.

ing difficulties later. Prompt attention to preventive cleaning is the only sure way to avoid loss of equipment use and extra work, time, tools, and materials required for corrective cleaning of a rust-clogged system. Effective and safe preventive cleaning requires that only approved cleaning compounds be used, and that all service operation specified in current directives be performed.

b. Cleaning Compound. The prescribed cleaning compound consists of the cleaner and neutralizer compounds packed in separate containers within a single package (para 2-22 (7)).

WARNING

Do not under any circumstances mix cleaning compound with antifreeze compound or corrosion inhibitor compound. Never mix the water and cleaning compound before putting it into the cooling system. Do not spill compound on skin, clothing, or painted portions of vehicle. If spilled, flush with clean water immediately.

c. Engine Temperature During engine idling periods required in cooling system cleaning processes, it is important to cover the radiator and keep the cover adjusted so that a temperature of 180° to 200°F is maintained. The engine develops so little heat while running without load that the thermostat valve remains partially or fully closed. Covering the radiator opens the valve quickly, but if the cover is removed, the valve will close again, even though the temperature gage shows little change. With flow to the radiator restricted by the thermostat valve, cleaning, inhibiting, and flushing are not effective.

WARNING

Remove radiator cap(s) slowly to relieve pressure and avoid injury to personnel.

d. Cleaning.

(1) Drain system by opening drain cocks. Make certain temperature of coolant has dropped considerably below 200° F before draining and refilling with cold water to avoid cracking block and head.

NOTE

Check with the cooling system drain caution plate on the instrument panel for position of drains, if the vehicle is equipped with such a plate.

(2) If necessary, use a wire to keep open any drain hole which tends to become clogged.

(3) Disconnect the radiator overflow return-tank, if the vehicle is so equipped.

(4) Close the drain cocks, pour water slowly into the radiator until the level is within two inches of overflow pipe.

(5) Replace radiator cap, cover radiator if necessary, start the engine, and run it at idling speed until temperature reaches above 180° F but not above 200° F. Then add cleaning components together into hot radiator

in amounts specified on cleaning compound container. Allow engine to continue running for 30 to 60 minutes.

(6) Stop engine and turn radiator cap to release pressure. As temperature rise can be expected at shut-down, coolant temperature should be allowed to drop considerably below 200° F before draining and refilling with cold water to avoid cracking block and head, then remove the radiator cap and drain the system completely.

CAUTION

Do not hold air or water hose too close to radiator, or use excessive pressure as damage to the radiator core may result.

e. Normal Flushing

(1) With engine stopped and temperature of coolant considerably below 200°F, open all drain cocks and remove engine block drain.

(2) Add clean water and, while so doing, start the engine at fast idle (drains open) Flush, continually flooding cooling system with clean water, engine running for 25 minutes.

(3) Stop engine, close all pet cocks, install engine block drain, refill with clean water, maintaining level in cooling system.

NOTE

If antifreeze compound is to be added after flushing the radiator, do not add Inhibitor, discard it.

f. Inhibiting. Add inhibitor in amounts specified on cleaning compound containers to filled radiator, start and run engine at idle until temperature reaches over 180°F, but not above 200°F.

g. Pressure Flushing

(1) To flush radiator (fig 2-20), proceed as follows:

(a) Remove both upper and lower hoses connecting the radiator to engine block.

(b) Clamp convenient length hose to radiator core outlet opening and attach another suitable length of hose to radiator inlet opening to carry away flushing stream.

(c) Connect the flushing gun to compressed air and to water line and clamp the nozzle of gun in the hose attached to the radiator outlet opening (lower).

(d) With radiator cap on tight, fill core with water. Turn on compressed air in short blasts to prevent core damage.

(e) Allow radiator to fill with water and again apply air pressure as before. Repeat this process until the water comes out clear and then proceed as in f above.

(f) Blow insects and dirt from radiator core air passages, using water to soften obstructions.

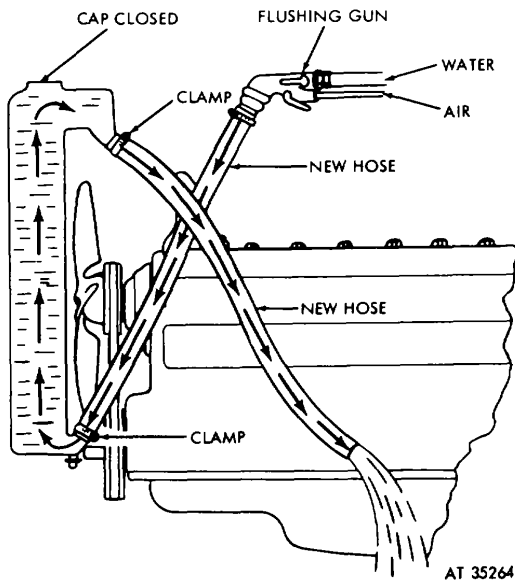

Figure 2-20. Pressure flushing of radiator.

(2) To flush engine block (fig. 2-21), proceed as follows:

(a) Remove thermostat and replace thermostat housing.

(b) Clamp flushing gun nozzle firmly to hose attached securely to engine water outlet opening.

(c) Fill engine with water, partly covering lower engine water inlet opening to facilitate complete filling.

(d) Turn on compressed air to blow out water and loose sediment. Repeat filling with water and blowing out with compressed air until flushing stream comes out clean and then proceed as in f. above.

(3) For most complete removal of sediment, repeat flushing of radiator core and engine block in opposite direction.

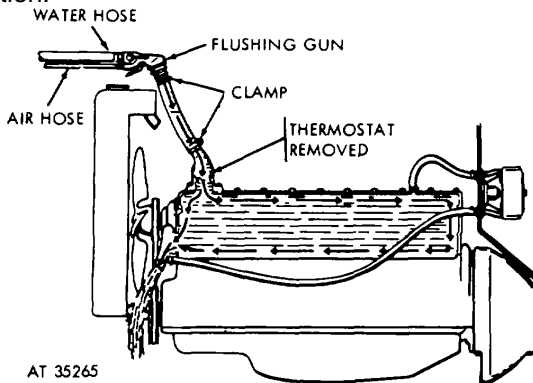

Figure 2-21. Pressure flushing of engine block.

(4) For badly clogged engine water jackets that do not respond to regular pressure flushing, engine should be

replaced and direct support notified for corrective cleaning.

(5) When vehicle is equipped with a heater or other accessories such as overflow tank connected to the cooling system, flush heater, following the same procedure used for the radiator core.

(6) After completing flushing operation and before connecting cooling system hose, clean all hose connections of both radiator and engine block. Clean radiator overflow pipe, inspect, and, if necessary, lubricate water pump, clean thermostat, and radiator cap control valves. Check thermostat for proper operation before installation.

h. Leaks. Close the drain cocks. Pour water slowly into radiator until the system is approximately half full. Start engine, run at idling speed, and fill the system completely. Stop engine and examine the entire cooling system for leaks. Carefully check the radiator hose connections, water pump mounting bolts, seal and gasket, thermostat mounting bolts and gasket, and cylinder-head bolts and gasket. Inspect radiator core for leakage. This is important because the cleaning solution may uncover leaks which existed but were plugged with rust or corrosion. Reconnect overflow tank if it has been disconnected and inspect caps and gaskets to be sure that they are in good condition and fit securely.

i. Coolant Service.

(1) When servicing the engine for operation at anticipated temperatures above 32°F, nearly fill the system with clean water. Add COMPOUND, inhibitor, corrosion (FSN 6850-753-4967), in the proportion of one container of inhibitor to each 4 gallons of cooling system capacity including accessories. Then complete filling the system with water. The capacity of the cooling system can be obtained from applicable technical manual.

(2) When servicing the engine for operation at anticipated temperatures below 32°F, use the procedure prescribed for reclaimed or new antifreeze compound, whichever is to be used. Inspect entire cooling system for leaks and replace any hoses not suited for extended use.

2-22. Special Instructions

a. One of the most common reasons for engine damage due to overheating is operation with coolant level low. Check coolant level daily before operation and add coolant as required to bring level to top of filler neck. If, at any time, coolant loss exceeds 2 quarts, the system should be thoroughly inspected for leaks (If no leakage is found, radiator cap, or pressure relief valve if so equipped, may be defec-

tive.) Maintaining coolant level at all times cannot be over emphasized.

WARNING

Remove radiator cap(s) slowly to relieve pressure and avoid injury to personnel.

b. During initial radiator fill, or refill after cooling system has been disturbed in any way to affect coolant level, it is important that coolant be added slowly, particularly the last few quarts. This is necessary to permit trapped air to escape and assure that maximum amount of coolant has been added to the system. The radiator should be filled to the top of filler neck. When filling or refilling cooling system remove the radiator cap (if system has two caps both must be removed) and proceed as follows:

(1) Add coolant slowly until radiator is completely filled (never add cold coolant to a hot engine). Excess coolant, if any, will be automatically expelled through the pressure relief. Replace cap(s).

(2) Run engine for about 5 minutes, or if possible until normal operating temperature is reached.

(3) Stop engine and recheck coolant level. Add coolant as required to bring level to top of filler neck and reinstall cap(s).

c. Defective or improper radiator caps (or pressure relief valve when applicable) can cause a loss of pressure or abnormally high pressure. Each cooling system is designed so that the engine will operate at a temperature that is expected to give the best performance. PSI (pounds per square inch) rating of the cap (or relief valve) determines the temperature at which coolant will boil. If cap or relief valve has a lower PSI rating (defective or improper) than system requires, coolant will boil at a lower temperature causing loss of coolant, which if not corrected, will result in overheating. If cap (or relief valve) has a rating too high, the boiling point is raised and more pressure is imposed on the cooling system than it was designed for. This may cause leaks in hoses, connections or radiators. The following points pertinent to radiator caps are provided for consideration.

(1) During normal operation, if coolant tends to stay above 200°F, radiator cap may be faulty.

(2) If pressure relief continues to expel coolant below normal operating temperature level, radiator cap may be faulty.

(3) On vehicles having radiator caps exposed and subject to damage by crew members stepping on them it is recommended that a "NO STEP" caution be stenciled on the deck near the radiator cap location.

(4) Pressure rating of the radiator cap is stamped on top surface of cap. Assure that cap is the one prescribed by applicable technical manual.

d. Problems with engine cooling fans, drive belts (or drive shafts if applicable) and pulleys have contributed to overheating problems. Inspection and maintenance of these items should include the following:

(1) Some early 6V53T engines and M551 ARAAV cooling fans were equipped with aluminum pulleys. Early failures resulted in a change to cast iron pulleys. Only cast iron pulleys are authorized for use on all cooling systems for 6V53, 6V5,3T and 8V71T engines.

(2) Be sure pulleys are tight and properly aligned. Burrs, nicks and other sharp edges can cause early belt failure and should be removed or pulleys replaced.

(3) Fan shafts should be examined for spline or bearing wear.

(4) Belts must be properly adjusted for effective operation. Belts that are too loose will slip and belts adjusted too tight will wear prematurely as well as impose undue strain on bearings, shafts and pulleys.

NOTE

Where belts are installed in multiples (two or more) they must be replaced in sets because they are matched sets. Replacing one belt in a set will result in belt failure since the tighter new belt will be doing all the work. Refer to the applicable technical manual for correct tension and adjustment procedure.

(5) Cooling fan blades must be free of bends, nicks, or breaks. These fans are precision balanced at time of manufacture. This balance can be affected by tears, bends and/or missing chunks which lead to early failure, possible damage to surrounding parts and injury to personnel.

(6) Observe fans, shafts, pulleys and belts in operation to be sure all items function properly.

e. Properly functioning thermostats are essential to efficient operation of cooling systems. Defective thermostats should be replaced but under no circumstances should engines be operating without thermostats. Assure that correct thermostat is installed in the proper place.

f. Clogged radiator cores restrict engine cooling. Every effort should be made to keep radiators as clean as possible. In some areas dust having a high clay content tends to adhere to the radiator core, frequent cleaning is essential to preclude overheating. Radiator maintenance should include:

(1) Remove dirt and other foreign matter from radiator air passages. Use compressed air or stream of water to dislodge imbedded material, do not use steam. When practical, direct air or water from direction opposite normal intake flow. A radiator and oil cooler cleaning tool is available for effective cleaning (10, fig 2-1).

CAUTION

Do not hold air or water hose too close to the radiator or use excessive pressure as damage to the radiator core may result.

(2) Radiator core cooling fins that have become bent should be carefully straightened to assure air passage without restriction.

(3) Overflow tube, when so equipped, should be cleared using a soft wire probe.

(4) Air intake grille and deck screens must be kept free of debris, boxes or baggage that may limit the flow of air. Extra items carried should be stowed without interference to air intake otherwise overheating may result.

(5) Oil spillage on radiator core will tend to hold dust

and block the flow of air Use care to avoid oil spillage on radiator Use cleaning solvent to remove oil spillage.

g. Coolant in radiator, cylinder block, cylinder heads, oil coolers, coolant tubes and hoses must flow freely without restriction by rust, scale or other sediment. The cooling system should be cleaned and flushed when necessary using compound 6850-598-7328. This compound will be used only as necessary and not as a routine maintenance procedure TB 750-651 establishes instructions for use.

h. Shrouds and panels must be in place to assure proper air flow and efficient cooling. Engine compartment panels, shroud seals, or hull inspection plates will when removed change the direction of air flow and adversely affect the cooling system.

Section III. TROUBLESHOOTING

2-23. General

This section contains a troubleshooting chart (Chart 2-2) and information for locating and correcting some troubles which may develop in the radiator. Each symptom of trouble given is followed by a list of probable causes of the trouble and suggested procedures to be followed to remedy the malfunction.

2-24. Procedures

a. If a specific trouble, test, and remedy are not covered herein, proceed to isolate the system in which the

trouble occurs and then locate the defect. Do not neglect use of any test instruments such as thermostat tester, cooling system tester, flo tester, combustion tester, and test bench that are available. Standard automotive theories and principles of operation apply in troubleshooting the radiator. Question vehicle operator to obtain maximum number of observed symptoms. The greater the number of symptoms of troubles that can be evaluated, the easier will be the isolation of the defect..

b. Good operational trouble analysis depends upon a sound and systematic investigation to determine the primary cause of malfunction.

Chart 2-2. Troubleshooting

Malfunction	Probable cases	Corrective action
1. Overheating	<p><i>a.</i> Clogged coolant passages</p> <p><i>b.</i> Disintegrated radiator hose</p> <p><i>c.</i> Clogged or bent radiator fins</p> <p><i>d.</i> Frozen radiator tubes</p> <p><i>e.</i> Shortage of coolant</p> <p><i>f.</i> Defective or missing thermostat</p> <p><i>g.</i> Dirty radiator</p>	<p><i>a.</i> Flush or boll radiator (para 3-11)</p> <p><i>b.</i> Replace radiator hose (para 1-5)</p> <p><i>c.</i> Spray clean, splice or replace radiator fins (para 3-33)</p> <p><i>d.</i> Clean with acid and boil (para 3-11)</p> <p><i>e.</i> Check for leaks Tighten clamps Replace coolant to proper level (para 2-20)</p> <p><i>f.</i> Replace thermostat (see pertinent maintenance manual)</p> <p><i>g.</i> Drain coolant, clean radiator Add fresh coolant (para 2-20)</p>
2. Overcooling	<p><i>a.</i> Faulty thermostat</p> <p><i>b.</i> Improper coolant</p> <p><i>c.</i> Extremely cold weather</p>	<p><i>a.</i> Replace thermostat (see pertinent maintenance manual)</p> <p><i>b.</i> Test coolant mixture Add or remove mixture to bring coolant to proper level (para 2-10)</p> <p><i>c.</i> Partly cover radiator Close hood louvers</p>
3. Loss of or abnormally high radiator pressure.	<p><i>a.</i> Defective or improper radiator cap</p> <p><i>b.</i> Collapsed or worn radiator hose</p>	<p><i>a.</i> Replace radiator cap (para 1-10)</p> <p><i>b.</i> Replace hose (para 1-6)</p>
4. Loss of coolant	<p><i>a.</i> Loose radiator hose</p> <p><i>b.</i> Defective or improper radiator cap</p>	<p><i>a.</i> Tighten hose clamps</p> <p><i>b.</i> Replace radiator cap (para 1-10)</p>

Malfunction	Probable causes	Corrective action
4. Loss of coolant (continued)	c. Rupture of radiator tube	c. Repair, splice, or replace radiator tube (s) (para 3-32)
	d. Unsoldered joints, cracked or worn spots or fittings	d. Solder (epoxy) aluminum radiators or patch defective areas (para 3-43)
	e. Open drain cock	e. Close drain cock
5. Corrosion	a. Air in coolant	a. Keep coolant level above radiator tubes (para 2-20)
	b. Impurities In coolant	b. Change coolant frequently (para 2-19)
	c. Contamination of coolant	c. Drain and clean radiator Add fresh coolant. Check coolant frequently for cleanliness (para 2-19)
6. Foaming of coolant	a. Combustion gas leakage into the coolant	a. Drain coolant Add water then run engine. If foaming continues, conduct combustion gas (para 3-21) and air suction test (para 3-19).
	b. Air suction into the cooling system	b. See a above

Section IV. COOLANT

2-25. Importance of Radiator Coolant

Line an endless belt conveyor, the flow of coolant is continually carrying a load of heat from the engine waterjacket into the radiator During operation, transfer of waste heat from inside engine to outside air through coolant must never be interrupted. Coolant plays as important a part in the operation of the automotive engine as fuel or lubricating oil.

2-26. Water as a Coolant

Water has always been the most commonly used coolant for internal combustion engines because it has good ability to transfer heat and can be readily obtained almost anywhere. Some properties of water, such as its boiling point and freezing point, limits its usefulness as a coolant. The natural corrosive action of water on metals is definitely undesirable.

2-27. Thermal Expansion

Antifreeze compound solutions expand slightly more than water when heated. When the temperature of a 50 percent antifreeze solution is raised from 40° to 180°F, the solution expands about 1/7 pint per gallon more than water under the same conditions. However, during very cold weather, the range between atmospheric and maximum operating temperatures is much greater than when water is used, and thermal expansion of solution is therefore a more serious matter. For example, the expansion of a 50

percent antifreeze solution when heated from -20° to 180°F is nearly ½ pint per gallon. If a 5-gallon cooling system containing a 50 percent solution where filled completely full with the coolant temperature at -20°, about 212 pints of solution would overflow out of the radiator by the time the coolant temperature had reached 180°F.

2-28. Boiling and Evaporation

a. *Nature of Boiling* Boiling causes coolant to change rapidly and violently from a liquid to a gas. Boiling of a liquid is controlled by two conditions, temperature of liquid and pressure upon it. Boiling of water takes place at 212° F under pressure of the atmosphere at sea level. When water boils and changes to a gas called steam, it is capable of expanding 1,600 times. Therefore, a gallon of water can make as much as 1,600 gallons of steam. However, when water boils in the limited space of an engine water jacket, this extreme expansion cannot take place. Under this condition, the force of the expansion creates steam pressure.

b. *Effect of Altitude* (fig. 2-22). Air pressure on each at sea level is about 15 pounds per square inch. This pressure becomes less at higher altitudes, and the reduced pressure causes water and other liquids to boil at a lower temperature. For example, the reduced air pressure at 1,000 feet above sea level lowers the boiling point of water from 212° to 210°F. At an altitude of 5,000 feet, the boiling point of water is only 203° F.

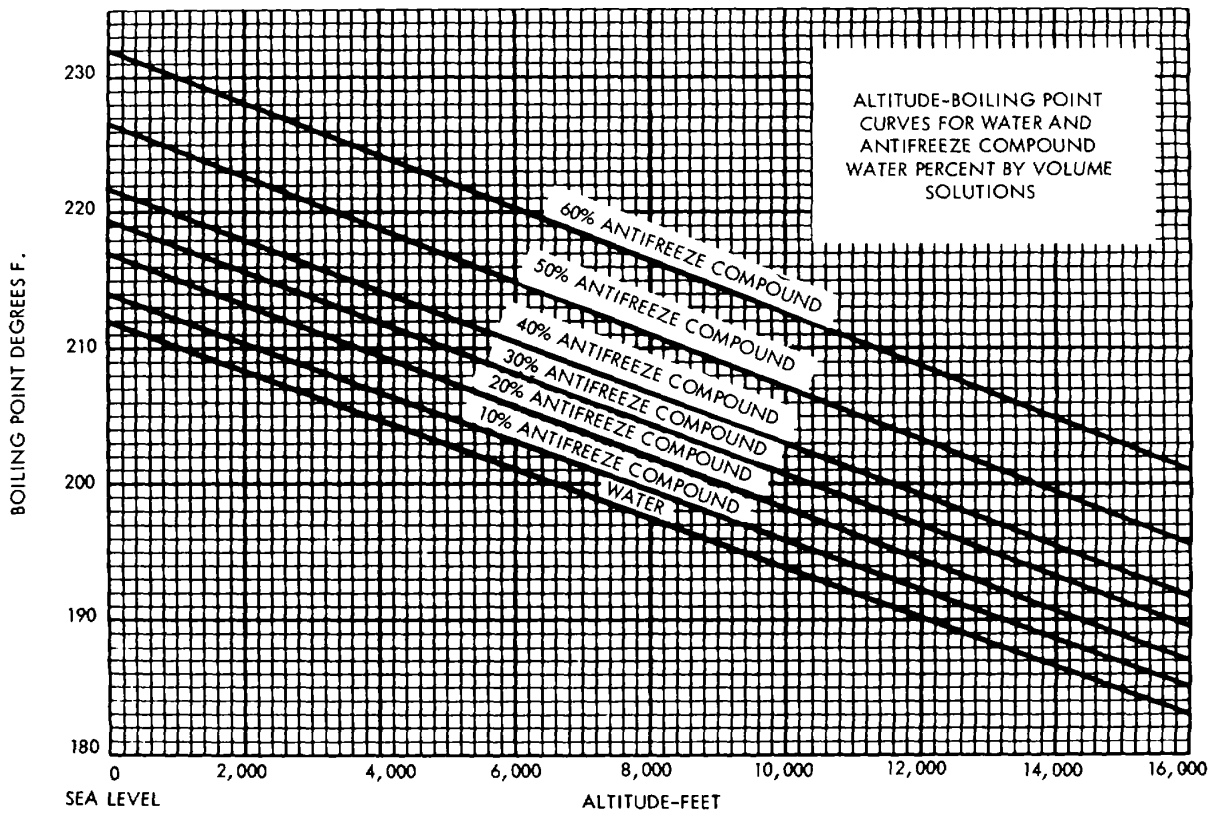

AT 35266

Figure 2-22. Effect of altitude on boiling points of water and antifreeze compound solutions.

c. *Effect of Pressure in the Cooling System* (fig 2-23). If the pressure in the coolant is raised above atmospheric pressure, the coolant will not boil until a higher temperature is reached. For each pound of additional pressure in the system, boiling point of the

coolant will rise about 30°F. In the military vehicle cooling system, pressure is applied to the coolant through use of a radiator pressure cap (para 1-10 and 2-9).

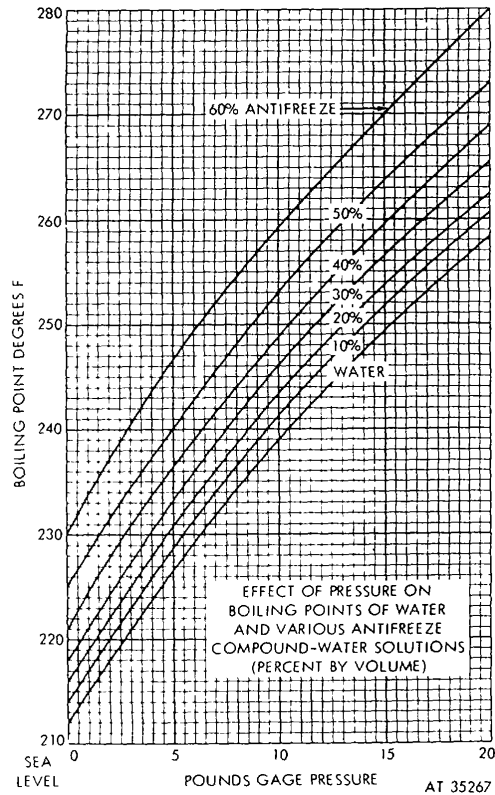

Figure 2-23. Effect of increased pressure in cooling system on boiling points of water and antifreeze compound solutions.

d. *Boiling During Engine Operation.* Violent boiling of coolant effects the operation of the cooling system in several ways. The formation of steam in the water jacket results in steam pockets which prevent the coolant from coming in contact with the metal. This interferes with transfer of heat to the coolant. Pressure developing from steam formation in the heater jacket forces coolant out the overflow pipe. Continued operation of the engine with boiling coolant can run the cooling system almost completely dry.

e. *After-boil* (fig 2-24) Following long, hard operation, boiling may occur after the engine is shut off, even though the coolant has not boiling during operation. This after-boil is caused by the rapid rise of coolant temperature in the heater jacket, sometimes as much as 20° F or more. The temperature rise is due to the fact that the coolant is still absorbing heat produced in the engine during operation and cannot get rid of it with circulation and air flow stopped. After-boil occurs less frequently and results in less overflow loss when the boiling point of the coolant is comparatively high. After-boil losses of coolant can be prevented by use of radiator pressure caps and overflow tanks.

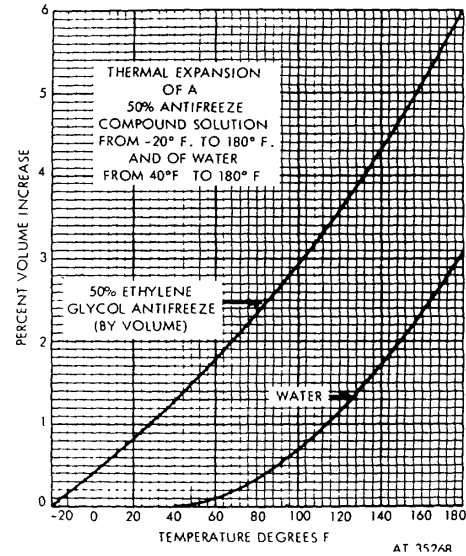

Figure 2-24. Expansion of water and antifreeze compound solution caused by heat.

f. *Evaporation.* Liquid can change to a gas by evaporation as well as by boiling. Boiling takes place within the liquid, and evaporation occurs on the surface. The rate of evaporation is controlled by a number of conditions which include the temperature of the liquid and the amount of surface exposed to the air. Water evaporates at all temperatures, but contrary to common opinion, the loss of water from the cooling system by evaporation is negligible as compared to other causes of coolant loss, especially in systems equipped with pressure caps. Evaporation of slight water leakage outside the cooling system may be so rapid that the leakage will be dried up as fast as it is formed, and there will be no moisture at the leak, especially when the system is hot.

2-29. Antifreeze Protection

a. *Freezing Damage.* When water freezes at + 32°F, it forms solid ice and expands approximately 9 percent in volume. This expansion takes place with a terrific force. If water is allowed to freeze in the cooling system, the force of the expansion will crack the engine water jacket (fig 2-25) and cause serious damage to the radiator and other parts. For this reason, the vehicle must never be exposed to freezing temperatures without antifreeze protection in the system.

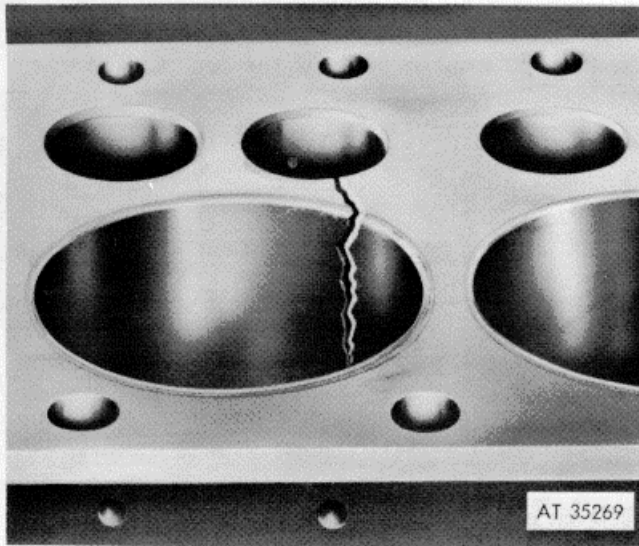

Figure 2-25. Heat cracking damage to cylinder block resulting from slush ice freezeup in radiator.

b. Antifreeze, Another liquid must be added to the water in order to prevent it from freezing. Water containing antifreeze will not cause freeze-cracking damage from expansion and will continue to circulate freely in the cooling system at very low temperatures if the proper amount of antifreeze has been added. Methanol, ethanol, and ethylene glycol are the types of antifreeze commonly used in civilian vehicles. However, antifreeze compound (ethylene glycol type) is the only type of antifreeze material authorized for use in water-cooled military engines.

(1) Antifreeze inhibited solution, FSN 6850-181-7929, may be retained in engine cooling systems for a two-year period from fill date.

(2) Arctic-Type antifreeze, 6850-174-1806, will be replaced on an annual basis, preferably at the beginning of the cold weather season.

(3) In climates where temperature does not fall below +32°F and where maximum engine cooling is required, the use of water with dissolved inhibitor, FSN 6850-753-4967, is authorized. Antifreeze protection during a seasonal period when temperature is expected to fall below +32°F is required. This protection consists of :

(a) One ounce corrosion Inhibitor for every two quarts water used in preparing the solution.

(b) Use of arctic-type antifreeze in areas where the lowest temperature encountered is below -55°F.

NOTE

In an emergency, where antifreeze solution or inhibited water is not available, the use of water without inhibitor is authorized on a temporary basis, with the circumstance noted on DA Form 91OR-14 At the earliest opportunity, necessary action will be taken to restore coolant to the

prescribed requirements.

c. *Antifreeze Protection*

(1) When cooling system protection is required for temperatures no lower than -55°F prepare a solution in accordance with Instructions in the furnished guide (Table 2-2).

Table 2-2. Table of Antifreeze Protections

Protection To	Pints of Antifreeze Compound
	Required to Make One Gallon of Antifreeze Solution
+ 10° F	2
0° F	2-3/4
-10° F	3-1/4
-20° F	3-1/2
-30° F	4
-40° F	4-1/2
-50° F	4-1/2
-60° F	

(2) In areas where the lowest temperature encountered is below -55°F, use arctic-type antifreeze, MIL-A-11755.

CAUTION

Do not dilute arctic-type antifreeze with water or inhibitor. It is ready for use as issued.

d. *Antifreeze Installation* Servicing the engine cooling system for operation at anticipated temperatures below +32°F is performed as follows:

(1) Completely drain coolant from system with engine warmed up above specified thermostat-opening temperature.

(2) Fill system with water, run engine at fast idling speed until thermostat full open temperature is reached, and drain water.

(3) Perform preventive cleaning of system if coolant is rusty or otherwise contaminated, or radiator is rusty or greasy inside (para 2-21).

(4) Determine required amount of antifreeze compound from protection guide (Table 2-2).

(5) Fill system about one-third full of water, add required amount of antifreeze, and finish filling with water, but leave room for expansion.

(6) Run engine at fast idling speed with radiator covered until thermostat full open temperature is reached to release any trapped air and thoroughly mix solution (fig 2-26).

(7) Tighten hose clamps and inspect for leakage.

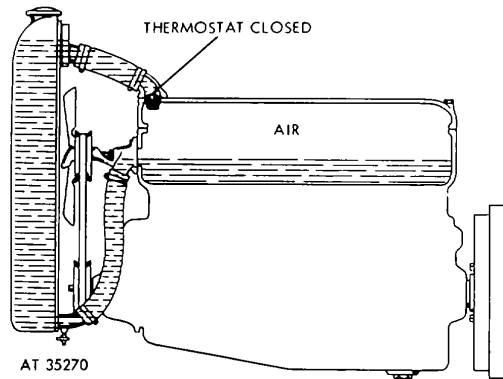

Figure 2-26. Air trapped in cooling system by thermostat being closed while system is filled.

(8) With engine stopped, test freezing protection of solution, and add water if necessary to bring coolant up to specified level. Complete details on antifreeze installation procedure will be found in TB 750-651. The capacity of the cooling system can be obtained from the vehicle maintenance manual.

e. *Slush Freeze-up* (fig 2-25). At temperatures below its freezing point, antifreeze solution does not freeze solid, but a mass of small ice crystals forms in the solution. The slush ice stops circulation through the radiator core. Even after the engine is started, the slush ice may not melt in the radiator, due to the cold draft of air from the fan. If operation is attempted before the radiator is thawed out, the engine will overheat, and steam pressure in the water jacket will force large quantities of solution out the overflow pipe. Serious heat-cracking damage may follow.

CAUTION

Always maintain adequate freezing protection against the coldest weather expected.

f. *Testing Antifreeze*. To be sure that antifreeze will give protection at the coldest temperature to which the engine is likely to be exposed, and to avoid overheating difficulties from slush freeze-up, the freezing protection of solution should be tested at least weekly and more often if the need is indicated because of water additions or weather conditions. Only hydrometers designed for testing ethylene-glycol type antifreeze compound will give an accurate reading. Check the accuracy of the antifreeze tester occasionally by taking readings on prepared solution of known freezing point. A mixture of one part of antifreeze compound and two parts of water should test to zero degree F, and one part antifreeze compound and one part water should test to -34°F. Tester manufacturers' instructions should be followed for proper use and care of the hydrometer. Accurate readings are not possible if the float and inside of the glass barrel are dirty.

2-30. Preventive Maintenance

During scheduled maintenance services, or during climatic change service, applicable testing of the system coolant and inspection of the cooling system, a through c below will be performed and recorded.

a. Testing for freeze protection, when applicable, by use of a combination antifreeze-and-battery tester.

b. Before reading tester, hydrometer barrel should be filled and emptied several times in order to equalize temperature of all parts. The first number or letter on the float above surface of the liquid is first read and solution temperature is then noted from the first division or number, above top of the thermometer column. These two readings should be made at the same time and as soon as possible after drawing solution into hydrometer. Freezing protection of solution is determined from float and thermometer readings by referring them to the protection chart on the hydrometer. Tests will be inaccurate if made immediately after adding either water or antifreeze. Most antifreeze hydrometers give best reading accuracy at solution temperatures around 110°F. Even with hydrometers designed to read at solution temperatures below 0°F, tests should always be made with temperature of coolant above 60°F if possible, because the solution is more viscous when cold. This condition prevents the float from finding its true level quickly and may result in a false float reading.

CAUTION

A freeze protection indication below -55°F will require partial antifreeze drain and replacement with water and inhibitor solution (para 2-29b(3Xb)). Freeze protection must not exceed -55°F.

c. Refer to TB 750-651 for testing procedures for reserve alkalinity.

2-31. Properties of Antifreeze Compound Solution

a. Freezing Protection (fig. 2-27). Missing antifreeze compound with water lowers the freezing point of the water in proportion to the amount of antifreeze compound used. The addition of 1 gallon of antifreeze compound to 3 gallons of water (25 percent concentration) lowers the freezing point of the water from +32°F to +10°F. A solution containing one-third antifreeze compound and two-thirds water will freeze at 0°F, while a solution which is half antifreeze compound and half water will protect against freezing down to -34°F.

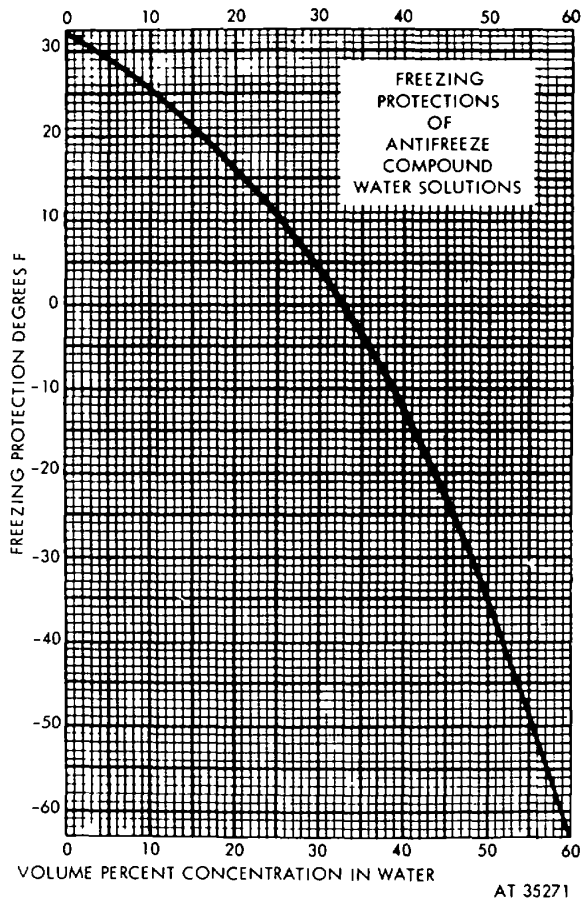

Figure 2-27. Relation between concentration of antifreeze compound in solution and freezing protection of solution.

b. *Properties of Antifreeze Solution.* Some of the differences between antifreeze solution and water have a bearing on cooling system preventive maintenance.

(1) *Freezing point.* Adding 60 percent antifreeze to 40 percent water lowers the freezing point of water in proportion to amount added until the lowest possible freezing protection, -62°F , is reached. Solutions which contain more than 60 percent antifreeze compound give less protection.

NOTE

When preparing antifreeze solutions, current directives should be consulted.

(2) *Boiling Point* The addition of antifreeze compound to water raises the boiling point of the coolant. A solution containing one-third antifreeze compound, protecting to 0°F , has a boiling point of 220°F as compared to 212°F for water, and a 60 percent solution boils at 231°F . Cooling systems can therefore operate at higher temperatures without boiling when using antifreeze

solution than when using water. However, 100 percent concentrated antifreeze compound has a boiling point far above safe operating temperatures for water-cooled engines and should not be used for coolant except with water added. Alcohol antifreeze solutions boil at temperatures below the boiling point of water.

(3) *Evaporation.* Loss of freezing protection from evaporation is no problem in antifreeze solutions. Practically all coolant losses are leakage and overflow losses of liquid, and the only way that freezing protection of the solution can be lost is through adding water.

(4) *Foaming of coolant.* Some natural waters have a greater tendency to foam than others, due to minerals or impurities contained in them. Contamination of antifreeze solution or aging of solution from extended service increases foaming tendencies. Foaming condition of coolant does not mean a head of foam on the surface of the coolant in the radiator, but refers to small air bubbles which are caught and held in the body of the coolant, giving coolant a milky appearance and increasing its volume.

(5) *Coolant leakage.* The leakage rate of inhibited antifreeze solutions is no more than that of water, although it may appear to be more. The explanation for the appearance of more wetness at small leaks with the antifreeze solution is that antifreeze compound evaporates more slowly than water. Leakage difficulties with either water coolant or antifreeze solution can be avoided only by proper attention to preventive maintenance leakage services (figs 2-2, 2-8, and 2-9).

(6) *Chemical Properties.* While water itself is chemically very stable, it attacks certain cooling system metals quite vigorously under the influence of heat and aeration, conditions constantly present during cooling system operation (para 2-16). To protect the system from corrosion, it is necessary to use corrosion inhibitor in water coolant. Inhibitors already contained in antifreeze compound have two purposes.

(a) They prevent the corrosive attack of water used in preparing solution.

(b) They prevent deterioration of the antifreeze compound, so that the solution remains noncorrosive for at least one winter's use under average operating conditions.

c. *Evaporation.* Any evaporation from antifreeze solutions is practically all water. Losses of solution from the cooling system by evaporation are negligible as compared to other causes of coolant loss (para 2-28f).

d. *Heat Transfer* Antifreeze solutions have slightly less ability to carry away heat than water. However,

this apparent disadvantage is offset to a large extent by higher boiling points. Therefore, no cooling problem is created by the use of antifreeze solutions for antifreeze protection in engines designed for water cooling.

e. Other Properties. Foaming and leakage tendencies, as well as chemical properties of both antifreeze compound and water, may affect cooling system operation and create maintenance problems. These properties are described in paragraph 2-31b.

2-32. Corrosion Inhibitors

a. The Corrosion Problem. Water has a natural tendency to combine chemically with iron and air in the system. This chemical action forms rust and may also cause corrosion damage to metal parts of the system. Details of the causes and effects of rust and corrosion are covered in paragraph 2-16.

b Nature of Corrosion Inhibitors. Protection of the cooling system against corrosion and rust formation is secured by the addition of special materials called inhibitors to the coolant. Although quantities of materials added to provide inhibitor treatment are very small, their effectiveness in preventing rust and corrosion is very great. Laboratory tests have shown that inhibitor treatment of water can reduce rusting of iron in the cooling system by as much as 95 percent.

c. Inhibitor in Antifreeze The proper kind and amount of inhibitor is added to antifreeze compound by the manufacturer. Consequently, there is no need for adding an inhibitor to fresh unused antifreeze solution. In fact, nothing but fresh, clean water should be added to new antifreeze when preparing solution.

d. Antifreeze Reinhibitor. The original corrosion inhibitor in new antifreeze may gradually be weakened and finally exhausted by extended use of the solution in the cooling system. It is therefore necessary to add corrosion inhibitor compound to antifreeze solutions that are to be used for a second season.

e. Inhibitor for Water. Inhibitor treatment is even more necessary when water is used as coolant than during the antifreeze season. Approved material which is provided for adding to water for summer rust prevention is the same as approved reinhibitor for use with used antifreeze solutions.

f. Effect of Operation on Antifreeze Inhibitors. Antifreeze inhibitors may slowly weaken with use and give less corrosion protection to the system. Contamination of solution also decreases inhibitor effectiveness and increase corrosion Complete exhaustion of corrosion inhibitors is generally indicated by an unusually rusty

condition of solution. Such a solution is not suitable for saving and reuse.

g. Conservation of Antifreeze. In the interest of conservation, antifreeze solutions-should be drained when danger of freezing weather is passed and suitable solutions should be saved for a second winter's use. Current directives specify that reuse of antifreeze solution should be confined to administrative vehicles. Clean solutions only should be saved. Solutions containing rust will contaminate clean solutions when mixed together in the same storage container, making the resulting mixture unfit for further use. Reclaimed antifreeze solutions should always be tested, and fresh antifreeze should be added if necessary to increase the freezing protection before such solutions are returned to the cooling system. As explained in paragraph 2-17b a rust inhibitor must be added to restore corrosion protection. It is desirable to make more frequent inspections of coolant appearance when using reclaimed solution, since the effectiveness and service life of the reinhibitor may not equal that of fresh solution.

2-33. Coolants

a. Approved Coolants. The only coolant authorized for ordnance vehicles is antifreeze compound (ethylene-glycol type).

b. Unapproved Antifreeze. Use of unapproved antifreeze material may cause overheating difficulties and damage to metal or rubber parts of the cooling system. If necessary to use unapproved material in a temporary emergency, it should be drained at the earliest possible moment, and cooling system should be thoroughly cleaned before proper coolant is installed.

c. Use of Engine Cooling System Cleaning Compound

(1) Engine cooling system cleaning compound MIL-C-10597 will not be used as a routine maintenance procedure each time antifreeze is added or drained from the cooling system. The compound will be used only when necessary to clean heavily rusted or partially clogged cooling systems.

(2) Engine cleaning compound MIL-C-10597 for cooling systems is designed to clean the interiors of cooling systems, to neutralize residual cleaning acids, and to coat the interiors with a silicate.

CHAPTER 3
REPAIR OF RADIATOR

Section I. RADIATOR CONSTRUCTION

3-1. GENERAL

a. The radiator of a motor vehicle is an essential element of the cooling system. It must function correctly if the engine is to escape serious damage from overheating. An engine is cooled by circulating water which passes through the cylinder block. It draws out the heat and then releases it to the air while flowing through the radiator. If this circulation is hindered or coolant leaks from the radiator, immediate repairs must be made to protect the engine.

b. Automobile, truck, and tractor radiators consist of two water tanks (upper and lower) joined by a core which does the actual cooling (fig 3-1). Water from the cylinder block usually enters the upper tank through the inlet, flows through the core, and leaves by lower tank. A 3/8-inch overflow pipe in upper tank (figs 3-1, 3-2 and 3-3) carries away excess steam or water. In the radiator assembly shown in figure 3-1, cast-metal tanks are bolted to the side members. Gaskets between the tanks and core make a watertight connection. Figure 3-2 illustrates a stamped metal radiator formed by soldering drawn or stamped metal tanks to the radiator core. The side members are straps of sheet steel soldered to the upper and lower tanks. This much lighter construction has generally replaced the cast metal type. In passenger cars and light-duty trucks, where it is usually concealed by the hood and radiator grille.

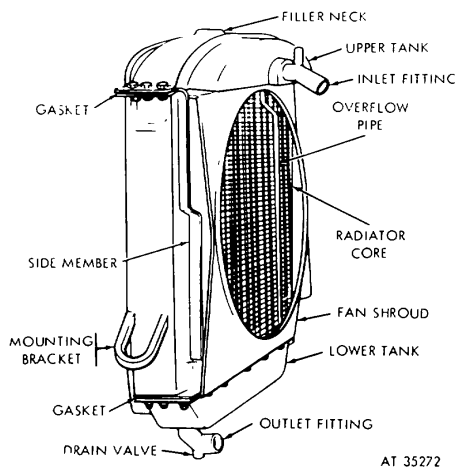

Figure 3-1. Cast metal radiator.

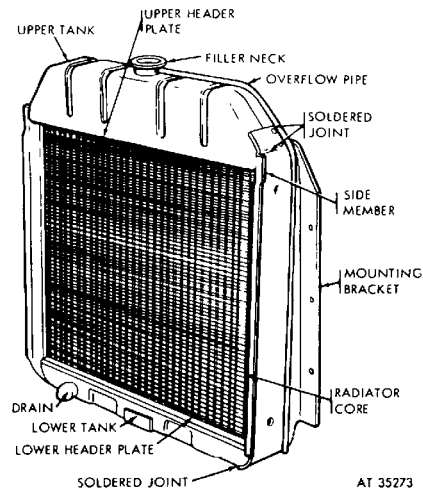

Figure 3-2. Stamped metal radiator.

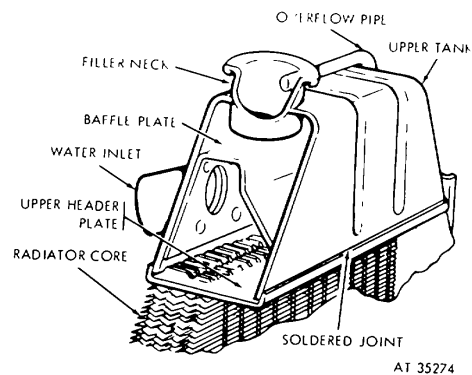

Figure 3-3. Stamped metal radiator tank (cutaway).

3-2. Water Tank

Almost all radiator tanks are cast or stamped in one piece to reduce the number of potential leaks. A baffle plate in the upper tank, below the filler neck,

eliminates excessive splashing and distributes the water uniformly over the tank. The cutaway view (fig 3-3) illustrates the construction of a stamped metal tank.

3-3. Radiator Core

a. *General.* Radiator cores are made with a large surface area of very thin sheet metal so that the heat of the water passing downward through the small passages may be readily transferred to the air. The water passages of the core are known as the "prime" radiating portion. Heat passes from the circulating water to the water passages and then to the fins where it is expelled to the passing air. The secondary radiation is as important for cooling as the primary radiation, be careful not to damage the fins.

b. Tubular Core

(1) Core, figure 3-4, is made of a multitude of vertical tubes, generally 1/4-inch in diameter (drawn or seam-welded) soldered through thin sheets of metal at the top and bottom, called header plates. The header plates form mounting pads for the upper and lower tanks and permit no passage of water from the tanks to the core except through the tubes.

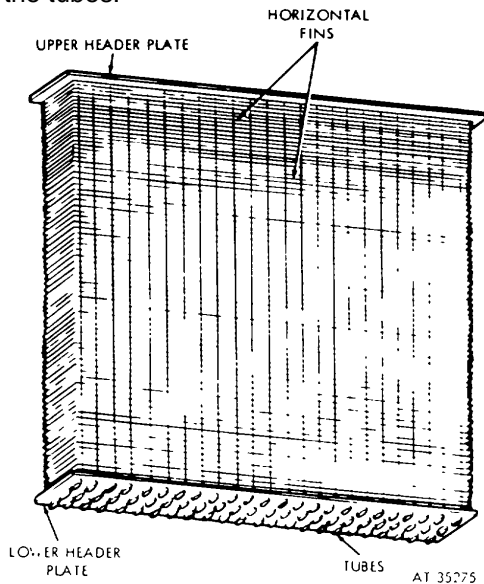

Figure 3-4. Tubular core.

(2) The tubes are generally spaced about 3/4 inch apart, in two to four straight or staggered rows (figs 3-5 and 3-6) 1/2 inch apart, across the width of the radiator. In a staggered row, twice as many tube rows are exposed to

the air entering the radiator, increasing the cooling capacity. Round tubes are easily broken by the expansion of freezing water, whereas oval tubes (fig. 3-4) will be distorted to some extent before breaking.

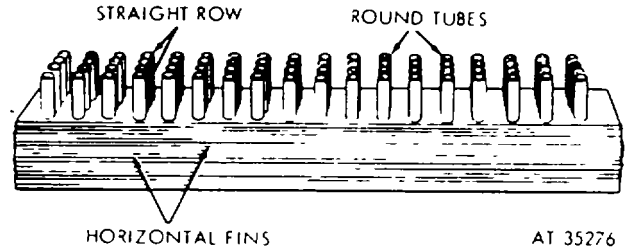

Figure 3-5. Tubes in straight row.

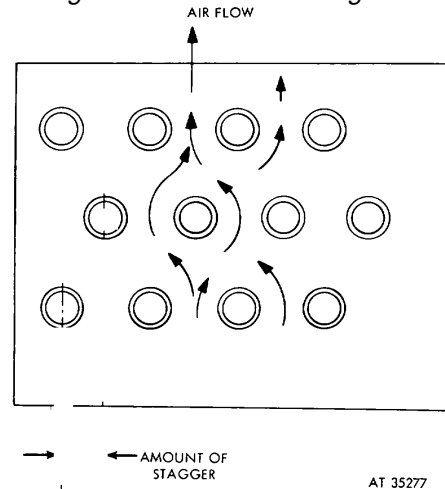

Figure 3-6. Tubes in staggered row.

(3) The radiating surface of these tubes is occasionally increased by spiral fins on each tube, or much more commonly, as in figure 3-4 by thin sheets of metal (horizontal fins) extending all the way across the radiator, 1/8 to 3/16 inch apart, in contact with each tube. The front edges of horizontal fins are usually crimped or bent back to a double thickness which strengthens the radiator core. In most radiator cores the fins are soldered to the tubes to speed the heat transfer.

3-4. Radiator Supports

a. Radiators in a motor vehicle are usually sup-

ported at the top and bottom. The top support is simply a tie rod extending to the cowl or cab front, the lower supports are fastened to the side rails or to a strong cross member at the front of the chassis. Radiator mountings should prevent all twisting strains, road shocks, and engine vibration from reaching the radiator core, which at best is delicately constructed and easily damaged.

b. The cast-type heavy-duty truck radiator shown in figure 3-1 has mounting brackets at the bottom of the side rails of the chassis. Small springs (coil or flat leaf) or rubber blocks are placed between the brackets and side rails to cushion the radiator.

c. Many radiators are housed in pressed metal shells. Fastened to the frame of the vehicle, the shell receives all the distorting forces that the frame receives. A shell may be detachable from the radiator assembly or built in it rests on a cross member of the frame, secured by studs and nuts, or is bracketed to side members, like the cast-type radiator. If the lower tank rests on the supporting member, soft pads of woven material are inserted to absorb road shocks.

d. The radiator shell shown in figure 3-7 consists of a U-shaped steel band, which is bolted to the front cross member of the chassis frame by two capscrews. Brackets on the pressed steel side members of the core are bolted to corresponding brackets on the U-shaped shell, holding the radiator assembly rigidly, and greatly facilitating its removal for repairs. If the radiator is spot welded and soldered to the mounting shell, the entire unit must be removed from vehicle before the core is accessible.

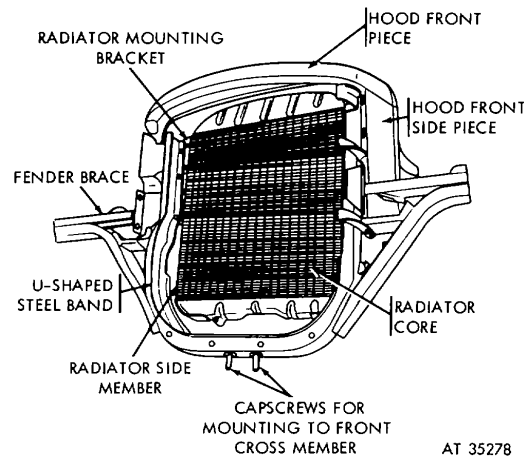

Figure 3-7. Radiator in U-shaped shell.

3-5. Radiator Fittings

The radiator fittings are the filler neck and inlet connection of the upper tank, and the outlet connection and drain valve of the lower tank. These are made of malleable iron or pressed metal. When they are manufactured as separate parts, they are brazed, soldered, bolted, or riveted to the tanks.

Section II. RADIATOR CLEANING

WARNING

Flux, caustic solutions and cleaning acids can cause skin irritation. Wash immediately with soap and clean water. If the skin comes in contact with these.

3-6. General

Radiator cleaning has three purposes to restore efficient cooling, to facilitate soldering, and to remove obstructions to water circulation. Various chemical salts and dirt found in the water of different localities, together with grease and oil that find their way into the cooling system, collect inside the water passages of the radiator and insulate the water from the metal or stop circulation. This overheats the engine. Rust, disintegrated rubber hose, and accumulated deposits from antifreeze or stop-leak preparations will have the same effect. The water passages may be cleared by pressure flushing, vat cleaning, boiling or rod cleaning. Dust, limit, and bugs often adhere to the fin

surfaces in sufficient quantity to restrict the air flow through the radiator and decrease its efficiency. Spray cleaning is then necessary.

3-7. Determining Extent of Clogging

To determine how badly a radiator is clogged without removing it from the motor vehicle, test it with a flow tester (para 3-18) which indicates the exact amount of gallons of water per minute that will flow by gravity through the radiator. Checking this reading against the flow rate of a new radiator will indicate the extent of clogging.

3-8. Flushing

a. *General.* Flushing is a process of forcing water by air pressure (approximately 5 pounds) through water passages of the radiator core or engine block. The same equipment is required for all methods of

flushing water pressure and air pressure (flushing gun) (7, fig 2-1). Flushing may be accomplished by the following ways.

(1) *Direct flushing.* Direct flushing is forcing water through the radiator core from top to bottom, as it flows in normal service.

(2) *Back flushing.* Back-flushing is recommended periodically and in particular when anti-freeze solution is changed. A back-flushing gun should be used for best results. The back-flushing gun employs both water and air under pressure. The intermittent application of air pressure causes turbulence in the water which aids the flushing action.

(3) *Flushing engine block.* Since the engine block shares the same coolant, when the radiator is flushed, the engine block should also be flushed. When a radiator is removed or when a new radiator is installed, engine block flushing is mandatory. If engine block is not flushed, loose scale will collect at top of core and eventually plug radiator.

b. Flushing Procedures

(1) Direct flushing.

(a) Screw radiator cap on filler neck and attach a lead-away hose to outlet connection of lower tank.

(b) With flushing gun in inlet connection of upper tank, fill radiator with water.

(c) Since water alone is often insufficient to break loose grease, sludge, rust, and scale within radiator, it may be necessary to add some good radiator cleaner.

(d) When deposits are loosened, turn water off and admit compressed air to radiator in short blasts, adding water between blasts until water drains out clear and at a normal rate. The air must be applied gradually, as the radiator will stand only a limited pressure.

(2) *Radiator back-flushing*

CAUTION

Do not use constant air pressure because danger of radiator rupture.

(a) Remove radiator cap, drain radiator and disconnect inlet and outlet hoses from radiator.

(b) Attach a lead-off hose to upper radiator inlet neck. This will divert the flushing water away from the working area and eliminate any water hazard to personnel or vehicle.

(c) Connect flush gun discharge hose to lower radiator outlet neck.

(d) Connect flush gun to both air and water supply source and operate water control on flush gun to fill radiator.

(e) When radiator is filled, replace radiator cap while continuing water flow. Operate air control valve on flush gun intermittently to produce short air blasts.

(f) Continue flushing with constant water flow and short blasts of air until clear water is discharged.

(3) *Engine block flushing.*

CAUTION

Do not use excessive pressure when flushing heater. Water shutoff valve on flush gun should be only partially open.

(a) Allow radiator hoses to remain disconnected. Disconnect heater hoses from the engine connection and not at the heater ends.

(b) Using an adapter bushing, connect the flush gun (4, fig 2-1) to one of the heater hoses. Flush heater using continuous water flow and intermittent air blasts as before.

(c) When heater discharge water is clear, remove flush gun but leave heater hoses disconnected.

(d) Remove engine thermostat. Attach flush gun discharge hose to thermostat opening with the use of the proper hose adapter.

(e) Open engine block drain cocks or preferably remove them. Make sure that drain cock openings and engine heater connections will not cause water hazard to engine parts or to personnel.

(f) Fill engine block with water from flush gun and operate with short air blasts until clear water is discharged.

(g) Replace all removed components and fill cooling system to proper level with prescribed coolant. Run engine a short time to remove trapped air and recheck coolant level.

3-9. Vat Cleaning

a Flo-Tester. Before vat cleaning, all radiators should be Flo-Tested (para 3-18). The gallons per minute (GPM) flow should be recorded to be compared with the GPM reading after cleaning.

b Cleaning

(1) *General.* Before repairing, a radiator should be cleaned both inside and outside. Outside cleaning is for ease of soldering during the repair. It is also important for removing any paint and oxide formations that might hide a small leak. Inside cleaning is required to restore cooling capacity, remove scale formations, dirt and oil that can temporarily seal a small leak. A heated vat (6, fig 2-1) with cleaning solution is the most effective method of cleaning. The vat must be large enough to contain the entire radiator. It should be constructed of material that is unaffected by the caustic action of the cleaning compound. The vat solution must be heated and some means of controlling and regulating the temperature should be used. Drains should be provided for changing the solution when it becomes dirty from continued use.

(2) *Hot cleaning vat solution.*

WARNING

If hot cleaning vat solution, muriatic acid or flux enters the eyes, wash generously for 15 minutes with clean water. Seek medical attention.

WARNING

When working with the hot cleaning vat, safety goggles, rubber shoes, rubber apron and gloves should be worn for protection against hot vat solution.

CAUTION

Adding large amounts of cleaning compound to a hot vat will cause violent boiling. Add only small amounts slowly. Never add water to the dry compound but instead add the compound to the water.

(a) The vat should contain a solution of water and radiator cleaning compound. It should be maintained at the proper temperature when in use. Cleaning compound is used in a quantity of 5 to 8 ounces per gallon of water. The most effective operating temperature is 190°F. to 200°F. The new vat solution becomes most effective after being maintained at operating temperature for a short period of time. This enables the chemicals in the compound to react and come into balance.

(b) To test solution strength, a simple test is performed with hydron paper. A small piece of hydron paper is dipped in vat solution and the color of the paper changes in relationship to solution strength. The resultant color change of paper is compared to a color chart included with the paper supply. The chart has three colors, labeled PH-11, PH-12 and PH-13. The proper solution strength is indicated when the wet paper matches the color of PH-13. To obtain a clean sample, be sure to blow any scum away from a small area before dipping paper.

(c) When mixing a new solution, add compound gradually in small amounts to cold water, then heat and maintain the solution temperature to about 195°F. To bring a weak cleaning solution up to strength, start with the addition of one ounce per gallon of the existing vat contents. A solution that is too strong, decreases cleaning effectiveness. When adding small amounts of compound, the vat can be at operating temperature.

(3) Radiator vat cleaning procedure

(a) The length of time required to clean a radiator will be governed by the condition of the radiator and the degree of plugging. The Flo-Tester will determine this. The average cleaning time in the vat is approximately one hour.

(b) Before cleaning, seal the oil cooler openings.

(c) Remove insects, etc., from outside of radiator with air gun before vat cleaning. This reduces contamination of the vat solution.

CAUTION

Aluminum radiators should not be cleaned with caustic base cleaning agents.

(d) Lower radiator in vat slowly until completely covered by solution. If violent boiling occurs when radiator first comes in contact with hot vat solution, immediately withdraw radiator from vat and thoroughly wash and flush with clean water. Violent boiling indicates that radiator or some of its parts are made of aluminum.

c. Flushing and Washing

(1) Thoroughly wash radiator externally and flush internally immediately after removal from the hot cleaning vat. This is necessary for removal of foreign matter that has been loosened by the vat cleaning process and to prevent formation of trouble-some oxides which interfere with soldering.

(2) After vat cleaning, flushing and washing, Flo-Test radiator again (para 3-18). If GPM rate is not up to specifications, repeat the vat cleaning and flushing procedure.

(3) If repeated cleaning is not satisfactory, remove tank for rodding. Flat steel cleaning rods are made for this purpose.

3-10. Drying

a. General

(1) After a radiator has been vat cleaned and thoroughly flushed, complete drying before leak testing is very important. If the radiator is not absolutely dry on the inside, small leaks may be sealed and not be evident during the air test. Small leaks are sealed by thin film surface tension of any moisture remaining in a radiator that is not completely dry.

(2) The air test will not simulate operating conditions which subject radiators to engine and road vibrations. Heat expansion and contraction, mechanical stress and other forces are exerted during operating conditions.

(3) A dry radiator will show every leak, no matter how small. If all leaks are exposed and repaired while on the bench, the reliability of the radiator can be assured.

b. Drying Procedure

(1) Seal all openings on radiator except inlet and outlet neck with push on rubber test plugs (11, fig 2-1).

(2) Using a hot air blower with suitable ducts, hoses, and adapters, connect forced warm air hose to inlet neck.

(3) Allow warm air to circulate through the water passages and discharge from outlet neck until radiator is completely dry internally.

3-11. Boiling Out Radiators

Sediment so firmly packed in the radiator that pressure flushing will not remove it must be boiled out using a suitable chemical solution, in a radiator test and repair stand (8, fig 2-1). The stand is made so that the radiator may be lowered beneath the surface on a lever-controlled rack. Leave it there long enough to loosen the scale, rust, and other foreign matter, and then rinse it with clean water.

3-12. Cleaning Solutions

To make a good cleaning solution, dissolve 1 pound of ordinary baking soda in 1 gallon of hot water. If a commercially prepared chemical cleaner for radiators is used, follow the directions on the container.

3-13. Rod Cleaning

If flushing or boiling is inadequate, scrape the inside surfaces of the water passages with a bristle brush or cleaning rod, which is merely a round wire with its end rounded to avoid puncturing the tube.

3-14. Spray Cleaning

Spray cleaning required the same equipment (7, fig 2-1) as pressure flushing. The spray of water under air pressure forces out dirt, bugs, and other material lodged between the fins, so that free circulation of air around all parts of each tube and fin is restored.

3-15. Radiator Cleaning Tool

a. General. The cleaning tool (10, fig 2-1) is designed to remove deposits of sand, oil, clay and other debris from the radiator cooling fins while installed in the vehicle. It consists of two tubes connected to a mixing

head which produces two high pressure jets of liquid/air mixture. The air supply tube has a push button valve with 1/4 inch female pipe thread for connection to a 5 cu/ft, 50 to 90 PSIG, air supply. The liquid supply tube is attached to a 3/8 in I. D. x 6 ft rubber hose for siphoning from a suitable clean container. The cleaning agent can be water solution of detergent and water, or non-toxic, non-flammable solvent and water. Mix one part of detergent or solvent to approximately five parts of water. A solution of detergent or solvent and water is recommended.

b. Cleaning Procedure

WARNING

Proper eye, skin, and clothing protection must be worn while operating this tool.

- (1) Remove radiator shroud cover.
- (2) Open drains.
- (3) Cover all exposed openings of the engine.
- (4) Connect tool to air supply and insert hose in container of solution.
- (5) Insert tool through shroud cover opening and saturate front and back of radiator with solution. Soak for approximately ten minutes.
- (6) Remove heavy deposits from face of radiator by brushing with medium stiff brush that will not damage the fins.
- (7) Blast radiator with air/liquid mixture holding head of tool approximately 1/2 inches from face of radiator. Alternate from back to front until a good flow of liquid through the radiator is observed over entire area.
- (8) Flush engine parts and radiator with clear water. Remove hose from container and use air to complete the operation.
- (9) Uncover engine openings and install radiator shroud cover.
- (10) Close drains.

Section III. TESTING

3-16. General

Before testing a radiator to locate leakage, inspect it carefully for visible leaks and solder them promptly, so that the test. A will be sensitive enough to reveal less obvious defects. There are two standard methods of testing one by introducing air (under light pressure) into the radiator, immersing it in water, and locating the leaks by the appearance of bubbles, and the other, by filling the radiator with water and locating the leaks through the moisture seeping through. Either test is satisfactory, although the air test method is preferred. Mark the leaks as soon as found to facilitate locating them during repairs.

3-17. Visual Inspection

Inspect outside surfaces of radiator for deposits of lime or magnesia, which is left by evaporating water and indicates leaks. Do not attempt to make an air or water test until all the leaks indicated by visual inspection have been repaired, for the effectiveness of these tests in discovering hidden leaks is lost when they reveal obvious leaks.

3-18. Flo-Tester

a. General. The Flo-Tester (3, fig 2-1) requires a water pump, a GPM flow gauge, a reservoir tank and connecting hoses and adapters. The water pump must have the required capacity in rated gallons per minute and the delivery rate must be controllable. The flow gauge must accurately measure and indicate the flow in GPM. Radiator manufacturers measure the GPM flow of new radiators to establish

performance specifications. The Flo-Tester measures the gravity flow rate of the radiator by maintaining the water level constant in the upper tank; while gravity force drains the radiator through the bottom outlet neck. The measured rate is compared to the manufacturer's specification. The percentage of restricted flow may be determined by the following formula:

$$\% \text{ plugged} = 100\% \text{ minus } \frac{\text{GPM Reading}}{\text{GPM Specified}}$$

Example : GPM Reading is 15
GPM Specified is 20

$$100\% \text{ minus } \frac{15}{20} = 25\% \text{ Plugged}$$

An accurate portable Flo-Tester will quickly determine the percent of plugging of a radiator without its removal from the vehicle. Performance curves for most radiator flow gauges show that they are accurate at only one GPM rate. This is affected by the fact that there is a non-linear relationship between pressure and the GPM flow of liquids.

b. *Flo-Test Procedure* (Downflow type, radiator not removed from vehicle)

WARNING

Water on vital engine parts can be hazardous to personnel and equipment.

(1) Remove radiator cap and drain cooling system (If antifreeze solution is clean and free from rust, it may be saved for continued use).

(2) Disconnect radiator inlet and outlet hoses at radiator necks.

(3) Connect Flo-Tester discharge hose to radiator inlet (top) neck. Make sure connection is tight and test pressure will not blow hose from neck connection.

(4) Examine lower outlet neck making sure that discharged water will not flow on vital engine parts. Use a deflector, made from sheet metal, canvas or rubber.

(5) Start Flo-Tester pump and gradually increase the water delivery rate until water level appears in upper tank. Adjust water delivery rate until water level remains constant in base of filler neck. Water level should be slightly below overflow opening, otherwise, an inaccurate reading will result.

(6) Record flow gauge reading and determine the percentage from the preceding formula.

(7) If reading is acceptable, reconnect hoses to radiator and refill with coolant. Run engine a short time to remove air pockets in cooling system and fill again to proper level.

(8) If reading is unacceptable, radiator should be either back-flushed or removed for vat cleaning and possible rodding.

c. *Flo-Test Procedure, Radiator Removed*

(1) Remove radiator cap and place radiator in normal operating position on Flo-Tester rack (3, fig 2-1) Position

so lower outlet neck of radiator will discharge back to Flo-Tester tank.

(2) Connect Flo-Tester output hose to upper inlet neck of radiator. Start Flo-Tester pump and gradually increase pump delivery rate until water level is raised to base of radiator filler neck. Maintain water at this raised level. Make sure water is not discharging from small overflow in filler neck.

(3) Observe and record GPM gage reading.

3-19. Air Leak Test

(Fig 3-8)

WARNING

The operating pressure of cooling systems is being progressively increased and some exceed 15 psi. When testing at pressures of more than 15 psi, the push-on rubber caps and plugs may blow off. To prevent this danger, clamps or wires should be used for holding those plugs or caps firmly.

CAUTION

Never attempt to air test a radiator with a direct air hose from the usually available 125 psi air source. Always use regulated air pressure.

NOTE

Before leak testing, the inside of the radiator should be thoroughly dry.

a. Examine the radiator tanks, core and fittings for physical damage and for large obvious leaks. Repair these obvious leaks before air testing.

b. Attach a filler neck adapter plug (Filler Neck Tester with air connection) to the filler neck of radiator. The adapter must seal the filler neck opening the same as the radiator cap but must provide a means of applying compressed air through a hose connection in the filler neck adapter.

c. To leak test a radiator and locate leaks, the radiator is submerged in a tank of water. Most radiators are tested at approximately 15 psi. An air pressure regulator and a low pressure gage is required for air pressure control.

NOTE

Radiators are tested at pressures of 3 psi above the maximum operating pressure.

d. Seal all other radiator openings with push-on rubber caps or plugs (11, fig 2-1).

e. Apply regulated air pressure to the radiator before submerging in test tank.

NOTE

Pressure is applied to radiator before submerging to prevent water from entering the inside of radiator through any leak.

f. With test air pressure applied, lower radiator slowly into test tank while observing for air bubbles.

g. Mark the source of the leak with scribe or other satisfactory means.

h. Some leaks are difficult to locate because of bubble deflections by the core fins. Lowering and raising slowly or reducing air pressure will have advantages for locating some difficult leaks.

i. To find very small leaks, place the bench light in back of the radiator so that the interior of the core can be seen. Stand the radiator on the bench, and spread the supposed leak with flux or soapy water from an

eyedropper, oil can, acid brush, or swab. Compressed air seeping through the leak will cause the liquid to foam

j. The number of leaks and their location and the general condition of the radiator will determine the advisability of repairing.

k. The leak test is conducted many times during most repairs and requires raising and lowering the radiator each time.

l. In some cases a new core may be recommended when there are a large number of leaks or the core shows deterioration.

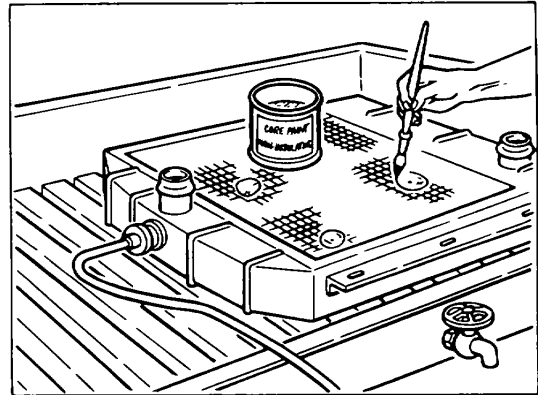
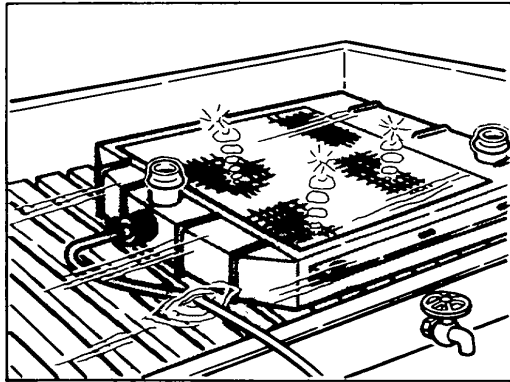

AT 35279

Figure 3-8. Leak testing a radiator.

3-20. Water Test

a. *General* The water test, so called because leaks are indicated by escaping water, replaces the air test when equipment is limited or supplements it when the air test is suspected of being inadequate. Sediment and lime deposited about leaky joints may be forced into the joints by air pressure when the radiator is air tested, sealing the leak. Leaks at the joint of tubes and header plates often refuse to show up under air pressure.

b. Test Procedure

(1) Dry radiator after repairing leaks found by air pressure, and test by water method.

(2) Remove plug from filler neck and fill radiator with water, being careful not to run it over or spill on the outside.

(3) Examine core carefully for leaks.

(4) Place air hose over lower end of overflow tube and hold palm of hand over filler neck, while a 5-pound pressure passes in against the water.

3-21. Combustion Leak Test

a. *General.* Engine combustion leaks may be

caused from leaky cylinder head gaskets, cracked cylinder walls and cracks in the valve cooling passages. Combustion leaks while the engine is operating will cause oil and combustion gases to contaminate the cooling system. Combustion leaks while the engine is stopped may cause the coolant to leak into the cylinders and the lubricating oil sump. There are many methods that can be used for locating combustion leaks.

b. *Testing with Manual Transmission.* This test requires that a discarded spark plug be adapted for an air hose connection. To adapt the spark plug, remove the porcelain element from the spark plug and braze a metal air valve to the top of the plug. For this test the following procedure may be used.

(1) Drain coolant to thermostat level and remove thermostat.

(2) Fill thermostat housing to top with water.

(3) Remove all spark plugs and install adapter in a spark plug hole.

(4) Lock engine in gear with valves closed.

(5) Apply 125 psi air pressure to the air connection on the adapter and observe coolant level in thermostat housing.

NOTE

The appearance of air bubbles in thermostat housing will indicate a leak.

(6) Repeat procedure on all cylinders until all leaks are located.

(7) When air pressure-hissing indicates the cylinder valves are open, the engine should be rotated until valves are closed.

c. *Testing with Automatic Transmission.* This test should be performed with engine cold. As engine-heats, water expansion could result in appearance of bubbles when there is no leak. This test will not locate the leak but only determine if a leak exists.

(1) Disconnect fan belt from water pump.

(2) Remove thermostat and fill thermostat opening with water.

(3) Operate engine for a short time and observe for air bubbles in thermostat housing while engine is running.

d. *Combustion Leak Tester.* For combustion leak testing, a Combustion Leak Tester (5, fig 2-1) is also recommended. This tester can be used on all types of vehicles and operates on a chemical color change indication. It requires only the removal of the radiator cap and will locate the leak with the removal of each spark plug wire in sequence.

3-22. Testing Radiator Caps

Radiator caps should be tested periodically for proper operation. A defective cap can cause loss of coolant, over-pressure damage or collapse of cooling system components. When testing radiator caps, the pressure seal on both the cap seating surface and the radiator filler neck should be carefully inspected. A cooling system tester (2, fig 2-1) should be used. These testers make use of a hand pump, a pressure gauge and adapter fittings for attaching to the various types of caps. The radiator cap seals should be moistened to assure that the test results are equal to operating conditions. To determine the pressure relief valve opening pressure, the manufacturer's specifications should be consulted. In some instances, the pressure is stamped on the cap. Be sure that the cap operates at the specified pressure. The vacuum protection valve can be tested by visually checking that the valve spring operates and the seal is good.

3-23. Cleaning and Painting

CAUTION

Radiators should never be painted with ordinary lacquers, enamels or paints as these insulate the heat transfer. This reduces the cooling efficiency. Always use Non-Insulating Radiator Core Paint.

After all leaks have been repaired, the radiator should be painted. A non-insulating paint should be used. Before painting, the radiator should be clean, dry and free of all flux residue.

NOTE

No more than one coat of paint will be applied to radiator cores on tactical wheel vehicles (3/4 ton through 10 ton trucks), except M39A2 series trucks, which will not be painted.

3-24. Testing Stand

The radiator test and repair stand (8, fig. 2-1) combines leak test tank, work bench and soldering equipment into one efficient unit. It has a motor driven work bench rack for raising and lowering the radiator at the test tank with minimum effort. When the rack is elevated above the tank water, it becomes a sturdy adjustable work bench. Soldering torch, air blow gun and regulated air connections are built in. Specially designed jigs for supporting the radiator in any position are attached to the unit. This well-designed arrangement promotes an organized systematic repair procedure with a saving of time and effort.

3-25. Field Test Tank

For field service a collapsible canvas tank (fig 3-9) will be provided in the third echelon equipment unit set No 1 for light maintenance companies. This tank consists of a one-piece canvas bag with wooden staves in pockets to hold the sides up and four round poles running through canvas loops to support the rim. A rubber mat protects the bottom of the tank from being torn by the radiator. When the tank is collapsed, two poles are removed and placed inside the tank, which is then rolled inside the mat and fastened with five flat metal hooks

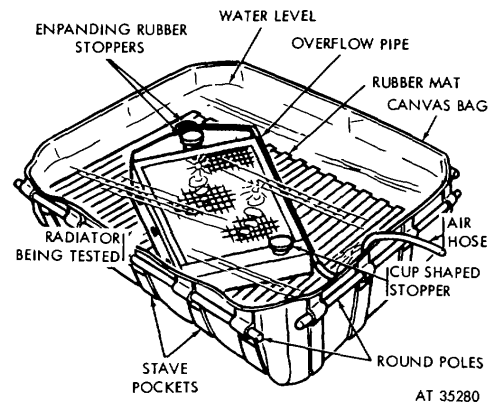

Figure 3-9. Collapsible canvas tank.

3-26. General

The step-by-step repair procedures included in this chapter are effected after the unit has been removed from the vehicle, vat cleaned, dried of all moisture and the leaks located.

3-27. Resolder Header Top Corners

a. *General.* The most frequent location of leaks is at the top corners of the radiator. When leaking, these corners should be completely resoldered. Resoldering should include two or three additional tubes adjacent to the leaky ones.

b. *Repair Procedure (Tanks not Removed).*

WARNING

There is a danger to personnel from hot blowing solder. Wear safety goggles, rubber shoes and rubber apron while blowing solder.

CAUTION

To blow away hot solder, apply point of torch flame to header and not the tubes. As the older solder melts, use blast of air from air blow gun. Repeat this process until all solder is removed.

CAUTION

Do not overheat fins. If they are heated to red, they will burn away. Apply only enough heat to melt solder.

(1) After leak testing, raise radiator from test tank and remove air pressure. Blow water from external fins and place radiator in upright position with fin side of header facing upward.

(2) Heat and raise fins in the area to be repaired if necessary. Heat fins slowly in repair area.

(3) Raise unbonded fins in repair area no more than 1/2 inch. Do not force fins but pry them only while solder bond is melted.

(4) Clean entire area by heating and removing hot solder from tube-header junctions with air blow gun.

(5) After solder is removed, flush and clean by squirting muriatic acid on repair area. Use syringe type squirt bulb made for this purpose. Apply flux with large flux brush and clean between tubes with radiator brush.

(6) Apply tinning mixture with swabbing brush and heat base of tubes along edge of header. Alternate use of flux and tinning mixture will give best results. Continue tinning until entire fin side of header is bright and clean.

(7) If difficulty is experienced in cleaning tube-header fin-side area, repeat use of muriatic acid, heat and flux. Dirt and oxides are washed away by brushing with this method. In extremely difficult instances, an abrasive blasting gun may be required.

(8) When repair area is absolutely clean and tinned, position radiator so that header is level and fin side to be soldered is facing upward.

(9) Begin heating and flowing solder about the header and tube joints. If radiator has three or more rows of tubes, begin heating and flowing solder about the header and tube joints. If radiator has three or more rows of tubes, begin with innermost tubes. As solder flows around innermost tubes, withdraw torch slightly to control heat. Continue soldering outer tubes in a similar manner. See Figure 3-10 for illustration of resoldering tubes into header from fin side.

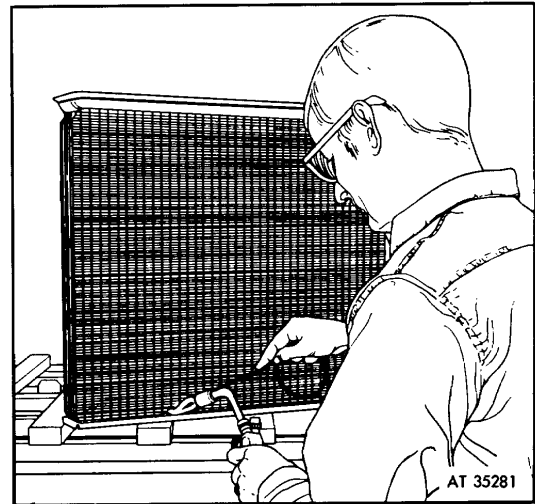

Figure 3-10. Resoldering header from fin side.

(10) Continue air testing and repairing until all leaks are repaired. Wash thoroughly to remove acid and flux residue.

c. *Reinforcements.* Tube reinforcements add structural rigidity to the tube-header junctions. These clips are formed from copper wire and can be placed around the tubes at the tube-header junctions and soldered in place. They are more necessary around the corner tubes where stress is greatest. The possibility of leaks occurring again is further reduced by use of these clips.

3-28. Resolder Entire Header

a. To resolder entire header, use the preceding method for cleaning, tinning, and soldering (para 3-27). After cleaning and tinning, began at one end of header and flow solder continuously around each

tube junction. Continue soldering without stopping until the other end is reached.

NOTE

If tank-header seams are overheated, they must be cleaned and resoldered.

b. After soldering, use air blow gun while radiator is submerged in tank approximately one inch below water surface. This will quickly flush away the flux residue from the repaired area. The air blow gun will agitate the water for a more complete flushing. Continue retesting until all leaks are repaired.

3-29. Resolder Header (Tank Removed)

a. If header has been removed for any reason and tube ends are freshly tinned, care should be used when soldering tubes to header. The same applies when repairing damage to a new radiator.

b. If tubes are soldered with header in horizontal level position, solder may run through tube-header spaces and plug tube openings.

c. When running solder on new or freshly tinned header, place header in vertical position (tubes horizontal) and run solder from "face" side, using similar procedure as detailed in this section. Figure 3-11 illustrates resoldering header with freshly tinned tubes and tank removed. Header is in vertical position.

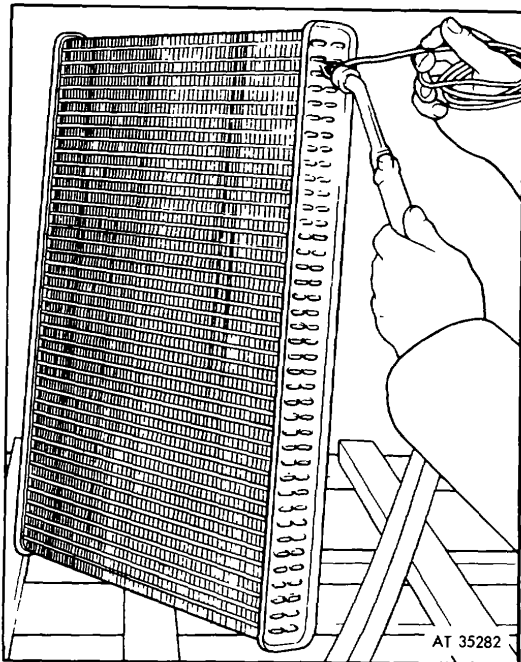

Figure 3-11. Resoldering header in vertical position (tank removed).

3-30. Removing and Replacing Tanks

a. *General.* After vat cleaning, if the Flo-Test shows excessive water passage restrictions, vat clean again. If continued vat cleaning will not remove flow restrictions, the top tank should be removed for rodding of tubes. To rod the tubes, insert a flat steel cleaning rod through each tube. When making certain types of repairs, it may be necessary to remove both tanks. The method used for removing the tank will vary in accordance with the type of header and tank attachment.

WARNING

Wear safety goggles, rubber shoes and apron when blowing solder.

CAUTION

Exercise extreme care to avoid flowing solder inside header and tank. Excessive solder could block the tubes.

b. *Solder-on Tanks.* These tanks are fitted to a raised lip around the edge of the header. The rim of the tank is attached by fitting the tank rim either inside or outside the raised header lip. To remove a tank from this type header requires removal of all solder from the lip channel. The following procedure may be used for removing and replacing the tank.

(1) Code-mark all components to be removed with a scribe so that they will be replaced correctly. A sketch may also be drawn of the core-tank-bracket assembly. Remove all necessary brackets and anchorages.

(2) Apply heat to lip of header and when solder is molten, blow away with air blow gun. Continue around the lip until all solder is removed from lip channel.

(3) While tank and header are still hot, heat one side of the header tank seam. Move torch alternately from one end to the other. This requires more heat and increasing torch flame for more heat distribution may be necessary. A larger torch tip may be required.

(4) When entire side is heated, place a wire brush handle or similar prying device inside one of the tank opening necks. Carefully pry the side loose. A small opening along the seam is all that is necessary. A slight jiggling motion should be used with very little force. The tank may be easily cracked when hot. The neck joint of the opening may become loose or bent from too much force.

(5) When side seam is loosened, repeat the procedure with other side and ends until tank is removed.

(6) Remove other tank, if required, in the same manner and perform the necessary repairs.

(7) Before replacing tank, check both header. and tank for proper fit and alinement.

(8) Clean and tin the seam portion of header in preparation for soldering to tank. Carefully inspect for cracks and other defects.

(9) Clean and tin the tank on both sides of rim portion in preparation for soldering to header. Inspect for cracks, etc.

(10) Place core assembly in a vertical position with header rim surface level. Fit tank to header and clamp in position using header clamp. Apply heat and flow solder in head lip channel until entire lip is completely soldered. Figure 3-12 shows a tank being replaced.

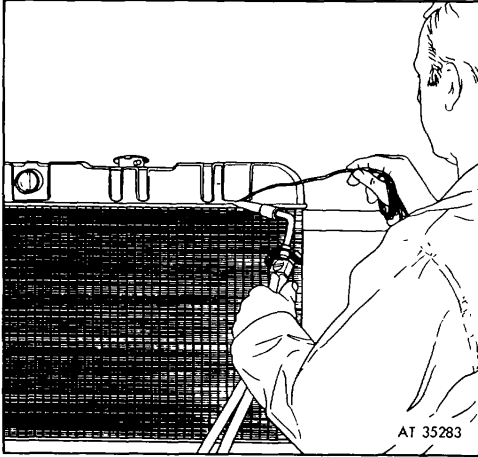

Figure 3-12. Tank being replaced.

(11) After testing replace all brackets and anchorages that were removed. Use appropriate radiator clamps and radiator side notchers. Soldering the brackets will require cleaning, tinning and clamping before soldering.

c. *Bolt-on Tanks.* Many heavy-duty and industrial radiators use bolt-on tanks (fig 3-13). These tanks are attached in a manner similar to a flange joint.

They use a gasket between the two adjoining flat surfaces. The following procedure may be used for repair.

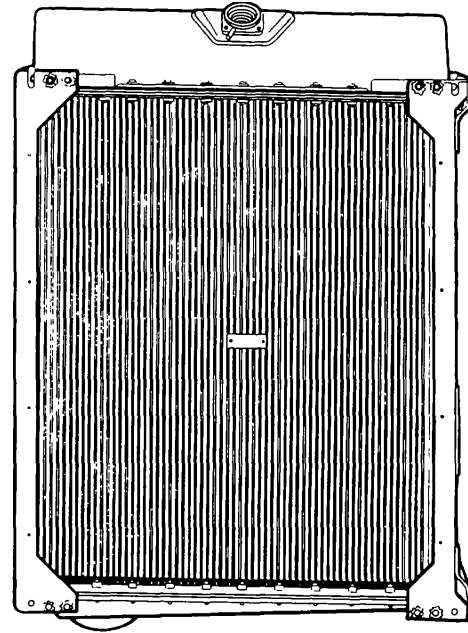

Figure 3-13. Bolt-on tank type radiator.

CAUTION

The smooth flange surface should not be bent or scratched on the seal surface.

- (1) Code-mark all components to be removed as directed in b above.
- (2) Remove bolts and gasket seal. Clean flange surfaces by scraping with a blade. Finish cleaning with muriatic acid until bright and clean.
- (3) Clean core in a hot cleaning vat.
- (4) Test core after cleaning. A Uni-Tester (fig 3-14) made for this purpose, may be clamped in place for air testing. If Uni-Tester is not used, construct a temporary "V" tank (e. below).

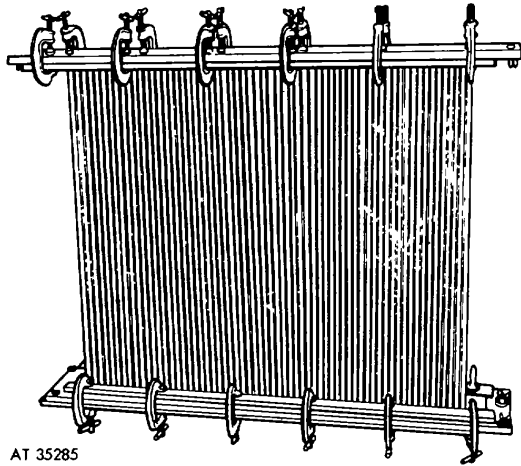

Figure 3-14. Uni-tester.

- (5) Leak test core and make necessary repairs.
- (6) Check radiator tank-header alignment by trial-fitting tank in proper position for bolting on.
- (7) Lift off tank and apply gasket cement to tank and header surfaces. Install manufacturer's recommended gasket. If gasket is not available, cut from sheet stock.
- (8) Place gasket and tank in place and bolt on. Tighten bolts alternately to prevent warping header or tank. Replace with new bolts if necessary.
- (9) Retest radiator for leaks using proper air pressure.

d. *Combined Solder-On and Bolt On Type Tanks.* Some radiators have bolt-on tanks and solder-on top tanks. With this type, only one test tank is necessary. If both tanks are bolt-on and are removed, two test tanks must be used. One will require the installation of an air connection. The air connection is made by punching or drilling a 5/16 inch hole in one of the test tanks. Solder a short length of 5/16 inch copper tubing to the hole.

e. "V" Test Tank.

(1) Construction.

(a). Cut a strip of 16 oz sheet copper large enough to cover the header to the outer edge and allow for an overlap. The overlap dimensions will depend on size of header. Allow enough overlap to form a slight "V" above the header water passages. One or two inches will usually be enough overlap for this purpose.

(b) Form a lengthwise "V" crease at the center of the strip.

(c) Flatten and form the sides of the "V" tank to

mate with the sides of the header for soldering.

NOTE

Be sure that "V" tank does not extend over header bolt holes.

(d) Clean along edge of header with muratic acid and wire brush. After cleaning, wash with clear water. Figure 3-15 illustrates a "V" test tank.

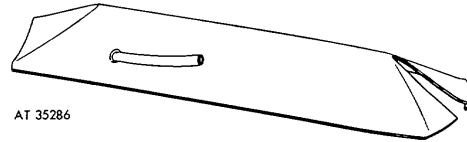

Figure 3-15. Temporary "V" test tank.

(2) Installation

(a) Clamp one side of "V" tank to the corresponding side of the header with vise-grip sheet metal pliers.

(b) Apply flux and tinning mixture along edges of clamped "V" test tank. A small section at a time may be clamped and soldered. Clamps are then moved until both edges of tank have been soldered. Leave both ends of test tank open.

(c) Cut a straight line from each end along the center line at the "V" crease for a distance of 2 or 3 inches. Overlap the cut ends and form to fit ends of header.

(d) Solder these overlapped ends together and then solder ends to header. The core is now ready for air testing. Figure 3-16 shows temporary "V" test tank being installed.

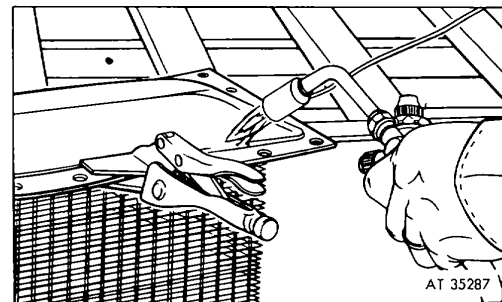

Figure 3-16. Temporary "V" test tank being installed.

(3) *Removal.*

CAUTION

Do not use too much heat. Excessive heat may create new leaks

(a) Heat and blow solder away from edge of "V" tank seam and pry loose while heated.

(b) Heat and wipe off excess solder from flange surfaces with wet cloth.

3-31. Removing and Replacing Headers

CAUTION

Do not attempt to remove header in one operation as damage to tubes may result.

a. Removal.

(1) With tanks removed (para 3-30) measure the distance between the top and bottom headers and make two stop blocks using 1" x 2" lumber cut to this measured distance.

(2) Starting at one end, heat the header on the face side (side through which tubes ends protrude) until solder is molten. Proceed until entire head is free.

(3) Remove excess solder with a wire brush.

(4) Insert a rod 1/4"x 18" or similar device between first and second row of tubes from one end.

(5) Heat header and using a ball peen hammer to gently tap side of rod near each side of header. Tap gently while heating until this portion of header breaks loose from tubes. After this small portion is broken loose, insert rod in next row, etc, and repeat procedure until header is free.

(6) Tap header lightly along entire length until header comes off. Figure 3-17 shows a header being removed.

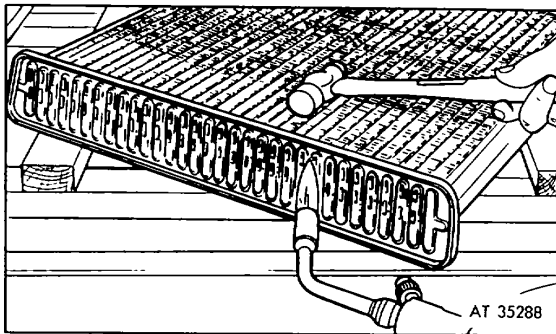

Figure 3-17. Header being removed.

(7) Clean and tin header openings and tube ends with tinning mixture and flux. When tinning tubes, place tubes in vertical position with tinned ends pointing upward. This prevents solder droplets from forming on sides of

tubes.

(8) Heat and blow off excess solder from header. Solder build-up in header openings may interfere with tubes fitting into header.

(9) Perform the required repair or replacement.

b. Installation

(1) Place header in position over tube ends.

(2) Use a tapping plate narrow enough to fit between tubes. Tap the plate with a hammer while moving plate alternately across header. Place measured stop blocks in position and drive header down on tubes slowly and evenly.

(3) Open all tube ends with a flat blade or screwdriver.

(4) Place header in a vertical upright position with tubes horizontal. Wash header and tube ends with flux solution.

(5) Starting at top end, heat and flow solder on face side (side through which tube ends protrude) until all tubes are soldered.

(6) Check other side of header to make sure solder flowed through space between tubes and header.

(7) Install tanks and leak test with the required air pressure.

3-32. Removing and Replacing Tubes

a. General. When a tube has several leaks, shows damage or deterioration, it is usually replaced. With corrugated fin type tubular radiators it is common practice to replace tubes when necessary. The tubes of continuous fin types are difficult to remove and are seldom replaced. However, they may be spliced with short sections of replacement tube stock (para 3-33). Tubes can be replaced while the tanks are attached.

b. Removal

CAUTION

Apply heat to tube and not the fins. If fins are overheated they will melt and stick to tube.

(1) Remove tube ends first. Heat tube at header end and raise adjacent fins by 1/2 inch. This allows access to the working area. Heat tube at the header and melt the solder bond in header.

(2) Twist tube end out of header by gripping with needle nose pliers.

(3) Repeat preceding step and remove opposite tube end. Double check to be sure that both ends of same tube are being removed.

(4) Heat tube from one end to the other while working it up and down.

(5) Grip tube with needle nose pliers and jiggle

continuously while cooling.

(6) The tube must be heated just enough to melt the solder bond between tube and fins.

(7) When tube is completely removed, align tube slot in fins and straighten any bent fins.

c. Installation.

(1) After removal of the old tube, clean tube slot with muriatic acid and tin.

(2) Select new tube of correct size. Check for correct fit by inserting new tube into each header opening and removing.

(3) Using aviation tin snips. Cut new tube approximately 1-inch longer than the distance between the two headers.

(4) Reopen collapsed ends with needle nose pliers.

(5) Solder nail to tube as shown in Figure 3-18.



AT 35289

Figure 3-18. Nail soldered to new tube.

(6) Insert tube end opposite nail into header opening.

(7) Position tube in slot.

(8) Place a small wooden block on tube and tap down lightly with hammer. Tap only enough to start tube in slot. Do not drive tube to final position in slot.

(9) Gently tap attached nail head with hammer. Drive tube toward opposite header opening.

(10) Before driving tube through header opening, make a scribe mark on tube 1/4 inch from end. This mark is used to determine when tube is centered between headers.

(11) Drive tube into header opening using the nail stem as a guide while tapping the nail head. Figure 3-19 shows new tube before driving to final position.

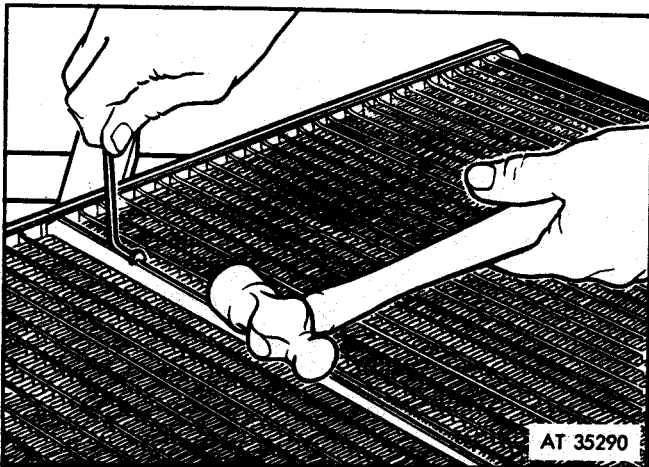

Figure 3-19. New tube before driving to final position.-

(12) When scribe mark indicates tube is in header, tap tube to its final position in slot. Use wooden block and hammer.

(13) Remove nail by heating temporary solder bond.

(14) Solder both ends of tube to header.

(15) Carefully bond tube to the fins by tinning and soldering. Apply heat to tube only. Flow a small amount of solder along both sides of tube.

(16) Leak test with the required air pressure.

3-33. Splicing Tubes

a. General. Leaks in tubes may be either spliced or repaired by sealing with solder. A tube that has been damaged in one area only, may be spliced with a new section of tube provided the greater portion of the tube is good. A small section of tube in the continuous fin type core may also be repaired by this method. Complete tube length replacement in continuous fin types is seldom attempted because of tube removal difficulty. A splice is recommended when the section of tube is collapsed or the hole is too large to rely patch with solder alone. If the damaged area is near the center of the tube length, a double splice may be used. If the damaged area is near the end of the tube, a single splice may be used because the other end will be installed into the header.

b. Single Splice Repair of Corrugated Fin Types.

(1) Heat and spread finds at end of tube to be repaired with needle nose pliers.

(2) Cut the damaged section of tube at one end with tin snips. The cut must be at an oblique angle to increase solder bonding area. An angle of 45° is recommended.

(3) When tube is cut, apply heat to the tube section and remove the cut section. Clean and tin the header area around the tube hole.

(4) Cut a new section of tube approximately 1/4 inch longer than the removed section. Obtain the new section from tube stock of identical size. Cut the new section at a square 90° angle. Open collapsed ends with needle nose pliers.

(5) Flare the angle-cut end of the tube to be spliced. Tin ends of tubes that have been cut.

(6) Fit the new section into the header hole and lower other end into flared end of tube being spliced. See Figure 3-20 for illustration of new section being installed.

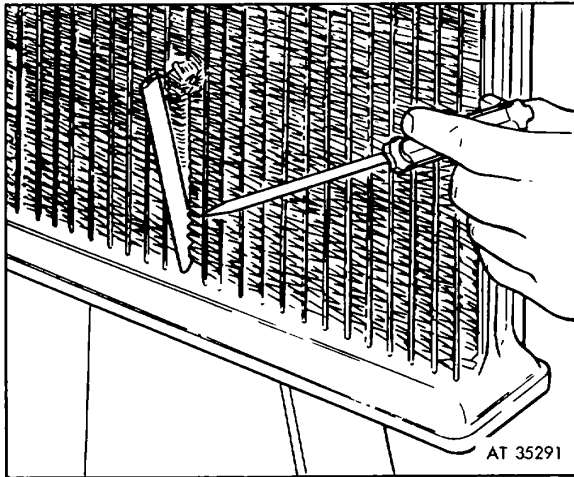

Figure 3-20. Tube section being installed (single space).

c. Double Splice Repair of Corrugated Fin Types

(1) Heat and spread fins at each end of the area to be repaired with needle nose pliers. Spread fins only enough to cut tube ends.

(2) Cut the damaged tube section at both ends with tin snips. The cut must be an oblique angle to increase the solder bonding area. An angle of 45° is recommended.

(3) Remove the cut section of tube.

(4) Cut the new section from tube stock approximately 1/2 inch longer than removed section. Cut new section at a square 90° angle. The tube stock may be one size smaller than the removed section for ease of fitting.

(5) Open collapsed ends of tube with needle nose pliers.

(6) Flare both ends of tube to be spliced so new section will fit inside. Tin all ends of tubes that have been cut.

(7) Fit new tube section inside flared ends.

Form flared ends around new section. Flux and solder spliced section. Be careful that solder does not flow inside tube. Figure 3-21 illustrates new tube section being installed.

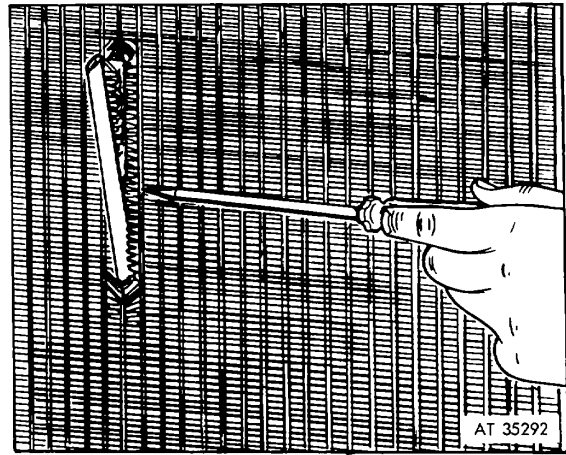

Figure 3-21. Tube Section being installed (double splice).

(8) Straighten bent fins at each end of repair area. Careful alignment and spacing of fins with the use of duck bill pliers will result in an appearance almost equal to a new radiator.

(9) Clean, flux and solder fins to tube section in usual manner. Use minimum amount of heat and small amount of solder.

d. Single Splice Repair of Continuous Fin Types

(1) Heat a small section of fins, grip with needle nose pliers and twist out fin sections. Remove evenly to provide a straight slot on each side of the repair area. Tear and remove only the number of fins that are required for the repair.

(2) Cut the damaged tube section at one end with tin snips. The cut must be at an oblique angle to increase solder bonding area. An angle of 45° is recommended.

(3) When tube is cut, heat and remove other end of tube from header by heating. Clean and tin header area around tube hole.

(4) Cut a new section of tube approximately 1/4 inch longer than removed section. Obtain the new section from tube stock of identical size. Open collapsed ends with needle nose pliers or suitable tool.

- (5) Flare the angle-cut end of the tube to be spliced. Tin ends of tubes that have been cut.
- (6) Fit new section into the header hole and lower other end into flared end of tube being spliced. Figure 3-22 shows tube being installed.

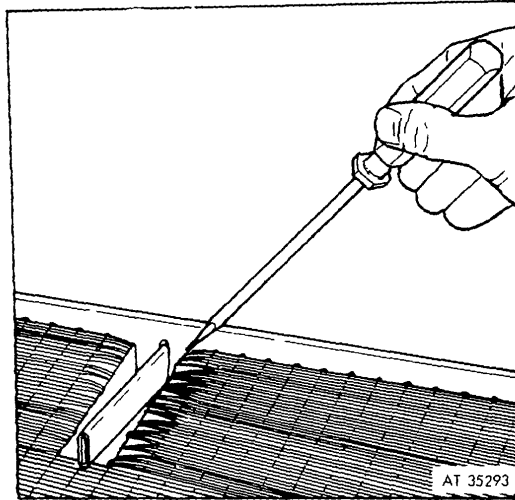

Figure 3-22. Tube section being installed (single splice).

- (7) Form flared end around new section. Apply flux and solder angle-cut end in usual manner as previously described. Be careful solder does not flow inside tube.
 - (8) Solder other end of tube in header.
 - (9) Straighten fins with duck bill pliers. Bond fins to tube using small amount of solder.
 - (10) Leak test with the required air pressure.
- e. Double Splice Repair of Continuous Fin Types
- (1) Heat a small section of fin, grip with needle nose pliers and twist out section. Remove evenly to provide a straight slot on each side of the repair area.

NOTE

Tear and remove only the number of fins that are required to make the repair.

- (2) Cut the damaged section of the tube at both ends with tin snips. The cut must be at an oblique angle to increase bonding area. An angle of 45° is recommended.
- (3) Cut a new section from tube stock approximately 1/2 Inch longer than the removed section. Cut new section at a square 90° angle.

NOTE

The tube stock may be one size smaller than removed section for ease of fitting.

- (4) Open collapsed ends of tube with needle nose pliers.
- (5) Flare both ends of tube to be spliced so new section will fit inside.
- (6) Tin all ends of tubes that have been cut.
- (7) Fit new tube section inside flared ends.
- (8) Form flared ends around new section, flux and solder spliced section. Be careful that solder does not flow inside tube. Figure 3-23 illustrates new tube section being installed.
- (9) Leak test with the required air pressure.

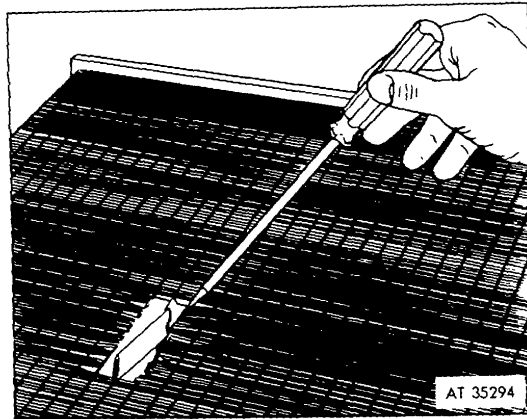

Figure 3-23. Tube section being installed (double splice).

f. *Replacing Fins*

(1) Install a fin section from a discarded corrugated fin type core or cut a sheet of thin copper to the depth of the removed fin space.

(2) After carefully fitting fins, solder finds to the tube section with small amount of solder to restore heat transfer. Refer to Figure 3-24 for illustration of replacing fins.

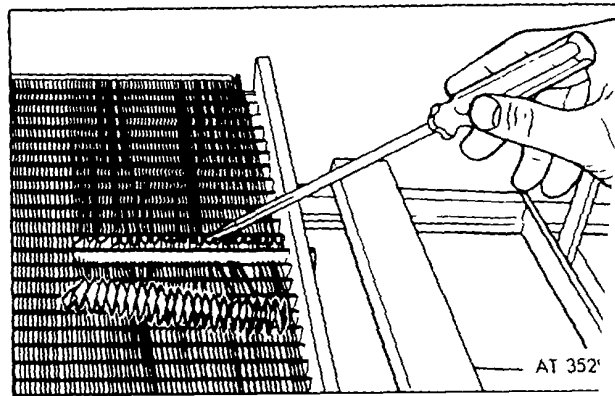

Figure 3-24. Replacing fins.

3-34. Repairing Tubes

a. *General.* Small leaks may be repaired by sealing with solder. Sealing large leaks with solder will only result in filling or plugging the tube. When large leak is pinched to prevent solder from plugging the tube, water flow through the tube is restricted. Therefore, it is recommended that only small leaks be repaired by sealing with solder. This type of repair consists of gaining access to the leak, cleaning, tinning and soldering.

b. *Sealing Tube Leaks With Solder'*

(1) Heat the tube in area to be repaired. Move or spread fins slightly to gain access to the leak.

(2) Heat the tube around the leaking area and brush on muriatic acid. Repeat this several times to clean the repair area.

(3) Heat the tube and apply flux and tinning mixture.

(4) When the area is completely tinned, heat and flow solder to cover the leak.

(5) Restore fins to their original position by using duck bill pliers.

(6) Test with required air pressure.

3-35. Blocking Tubes

Most radiators are designed with an overload capacity. When tubes are blocked or plugged, the overload capacity is decreased in proportion to the number of tubes blocked. Blocking of tubes is more economical than replacing or splicing. A limited number may be blocked in most applications. Radiator cores in tactical wheel vehicles (3/4 ton through 10 ton trucks) with not more than two tubes blocked are acceptable, except M39A2 series trucks, which must have all tubes functioning. If a tube is split lengthwise or severely damaged, it may be blocked at each end. When a tube is damaged along its length in a large area, it can be disconnected from the headers and both header holes filled with solder. Tubes can also be blocked by punching a hole approximately 2 inches from each end. Flare the holes, clean, tin and fill with solder.

3-36. Patching Headers and Tanks

a. *General.* Cracks occur in headers and tanks from temperature and pressure changes. Other ruses are mechanical stresses and vibrations during normal operation. These cracks, if repaired by lder alone are likely to recur. Solder alone contributes very little to structural rigidity and strength a copper patch (a thin patch cut from 16 oz copper let) is soldered over a crack, the bonding area of solder is greatly increased. This

strengthens the weakened area. A patch usually results in a repair sufficient strength to prevent recurrence of the crack. When a header is cracked between tubes, a noticed patch may be used. Cracks that are located on a multiple contoured surface are usually brazed or silver soldered.

b. *Patch Repair*

(1) Cleaning the area with alternate use of heat and muriatic acid is usually sufficient. For more difficult cleaning, use wire brush and muriatic acid. On extremely difficult multiple-contoured surfaces, abrasive blasting may be required.

(2) Tin an area at least 1 inch larger than all points of the crack. Cut a patch from 16 oz copper sheet (this material is approximately 0.21 inches thick) to a size that covers the tinned area. Tin both sides of the copper patch.

(3) Check fit and size of copper patch by placing it over the crack. Be sure that it is formed to the surface contour and covers the crack with the surface contour and covers the crack with the proper overlap. Remove patch and position radiator so that repair surface is level.

(4) Heat and apply a thin layer of solder over the crack and tinned area.

(5) Position patch, heat and flow additional solder around edges of patch and cool with water.

(6) Wash patched area thoroughly and leak test it proper air pressure Figure 3-25 illustrates a tank patch repair and Figure 3-26 shows a header repair using a notched patch. (Before soldering).

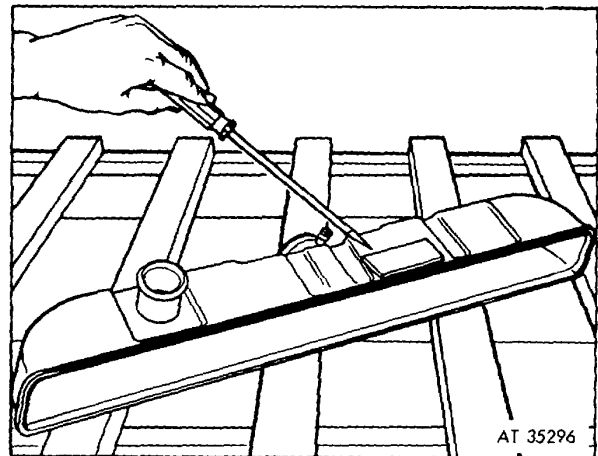

Figure 3-25. Tank patch repair (before soldering).

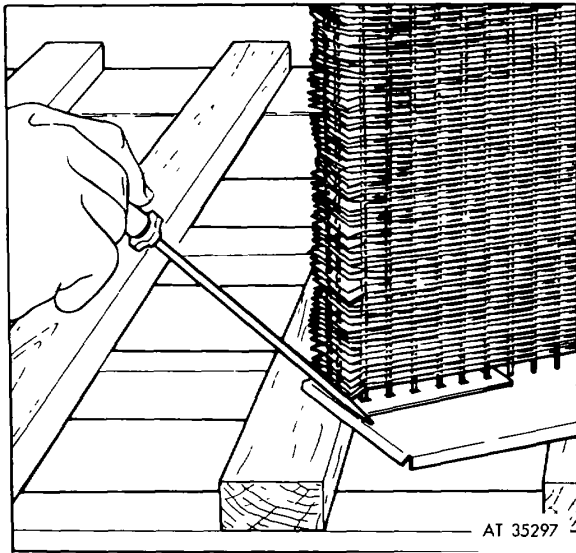

Figure 3-26. Header repair using a notched patch (before soldering).

3-37. Removing and Replacing Overflow Pipes

- a. Heat overflow pipe with the needle flame of a torch.
- b. When the solder becomes plastic, reach down into the filler neck with fingers and push pipe out past tinned portion, then, from the outside, pull it free.

NOTE

If overflow pipe is pulled first, it will probably break.

- c. Clean, tin, and flux end of pipe, and insert it in the filler neck.
- d. Putting the flame on Joint, touch pipe with a solder rod. When solder begins to flow into Joint, remove torch quickly and let solder harden. Unless the fusing metal enters the joint, it will give little strength.
- e. Resolder lower end of overflow pipe securely to lower tank or radiator side members, fastening. It with clips where possible.

3-38. Radiator Opening Neck Repair

a. *General.* A crack at the base of filler neck, inlet neck or outlet neck may be repaired in the same manner as the foregoing, with the exception of shaping the copper patch which is cut and formed for soldering to both the tank and the neck.

b. Repair Procedure

- (1) Cut a number of slits along the center hole radius and bend to a 90° angle for soldering to neck.

NOTE

The 90° bends provide reinforcement to the neck base
 (2) The flat section of the copper patch is soldered to the tank. See Figure 3-27 for an illustration of a repair to an inlet neck.

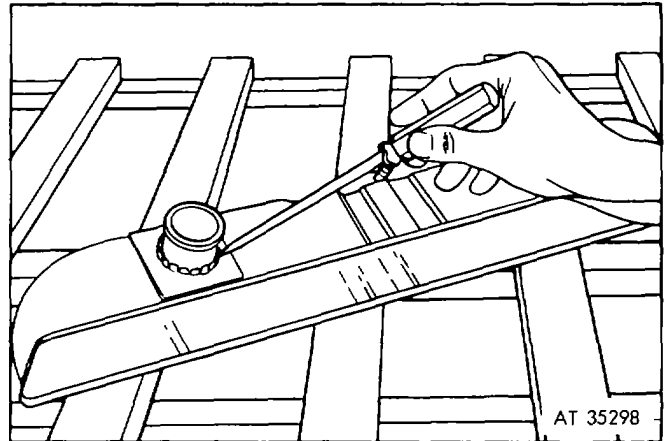

Figure 3-27. Inlet neck repair.

3-39. Major Core Repairs

a. *Straightening.* A bent radiator core can be straightened provided the bend is gradual, but not if it is so sharply kinked that the water tubes or passages are collapsed.

(1) Straightening is done best in a press (9, fig 2-1) with boards above and below the core to spread the pressure and protect the air fins.

(2) If no press is available, place the core between boards on a flat surface and hammer the upper board to force the core back into proper shape.

(3) A core that has been slightly sprung by an impact at the side may be straightened in a simple frame such as that illustrated in Figure 3-28.

(4) Fit both clamps loosely on the core at top and bottom header strips with the lever in the position shown, and tighten the clamp bolts as far as they will go.

(5) To straighten the face of core remove core and repeat operation with the clamps this time at each side of the core.

(6) The frame may be further used to straighten a side thrust in the core. The clamp to which the lever is attached should be secured on a bench and the core fastened in it with the high part of the thrust upward.

(7) Fasten the second clamp bolt until core is straightened.

NOTE

Removing the radiator tanks is not necessary unless the tanks are damaged.

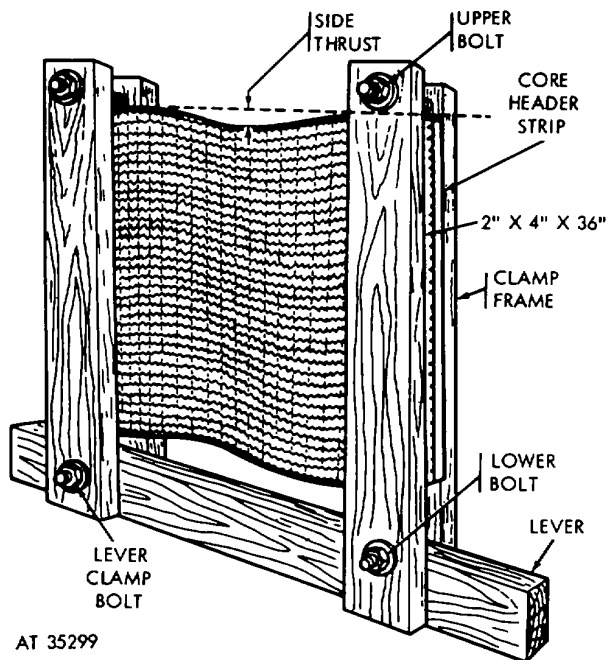

AT 35299

Figure 3-28. Frame for straightening sprung core.

(8) After a core has been straightened, the air fins must also be straightened and all leaks repaired.

(9) An impact at the side of a radiator may damage only the edge of the core. In a tubular core, when the water tubes are only partially closed but not torn, reopen them by plunging a blunt rod down the entire length of the tube.

Section V. REPAIR OF ALUMINUM RADIATORS

3-41. General

Aluminum weighs less than half as much as copper or brass and is a good heat conductor. One of the disadvantages is the difficulty of repair by welding. Epoxy repairs are usually satisfactory but aluminum welding may be more reliable. Because pure aluminum has a very small range between welding and melting temperatures, aluminum radiator repair requires a welding proficiency that is difficult to develop.

3-42. Leak Testing

CAUTION

When leak testing aluminum radiators, be sure that the test tank water is clean. It should not contain any trace of flux, acid or caustic solutions. Water in a test tank has been used for brass or copper radiators should not be used.

NOTE

If the tubes are too severely damaged to be reopened by rodding, install a new core section.

b. Recoring. When the entire radiator core has been damaged beyond repair, but the tanks are undamaged, substituting a new core will make the repaired assembly as serviceable as new. An impact at the front fender or radiator assembly may force the radiator core back against the revolving fan blades. Where the fan blades only polish the edges of the core air fins, it is only necessary to relieve the brightness with a little paint. Where the fins have been flattened to close up the air cells, the fins can be straightened. Where the fan cut is so deep that it has gouged out the solder or cut the water tubes, it is necessary to replace the damaged core.

3-40. Mounting Assembly

a. General. Radiator supports, whether connected directly to the radiator or to the shell, should be able to carry it properly.

b. Repair

- (1) If a soldered shell has worked loose, resolder it
- (2) If the shell is bolted to core channels, solder them rigidly to tanks and straighten or brace them so that they will not become loosened and allow the radiator to be worn or shaken to pieces.
- (3) Reinforce the top support rod connection to withstand the thrust or pull at this point.

a. Aluminum radiators are Flo-Tested in the usual manner (para 3-18).

b. Clean aluminum radiators by the flush gun method or vat cleaned in a 10% solution of trisodium phosphate and water at 140° F.

c. After Flo-Testing and cleaning, Flo-Test a second time to determine the effectiveness of cleaning *d.* Dry inside of radiator thoroughly by circulation of warm air inside radiator (para 3-10).

3-43. Repair Procedure

CAUTION

Standard brass-copper repair procedures should not be used on aluminum radiators. Some of these standard procedures are damaging to aluminum radiators.

NOTE

Leaks in aluminum radiators are most commonly repaired with epoxy compound. Since the work life of the prepared epoxy compound is limited, all leaks should be exposed and repaired using one batch of epoxy compound.

- a. Leak test radiator (para 3-42),
- b. If leak is in tubes, the fins surrounding leak should be removed with duck bill pliers to facilitate cleaning and repairing. Remove fins to a depth of 1/4 inch beyond leak to allow space for cleaning and applying epoxy
- c. Clean area to be repaired. The area must be absolutely clean. Do not use muriatic acid. Clean with wire brush, sandpaper or air blaster. An industrial blasting machine will quickly and completely clean cracks and

hard-to-reach areas. In addition to cleaning the metal, it also etches the metal for a positive bonding surface.

d. Use air blow gun to remove any foreign particles from repair. Wipe surface with a clean cloth that has been saturated in lacquer thinner. Before applying epoxy, the surface to be repaired and the small surrounding area should be thoroughly dry.

e. For repairing with epoxy, an epoxy repair kit is recommended. The kit is supplied with two separate tubes, one contains resin and the other hardener. For use, mix equal lengths (not portions) from each tube and blend with mixing stick which is included. Mix until compound is a uniform grey color. The working life is approximately 15 minutes, depending on room temperature. See Figure 3-29 for illustration of simplified epoxy repair.

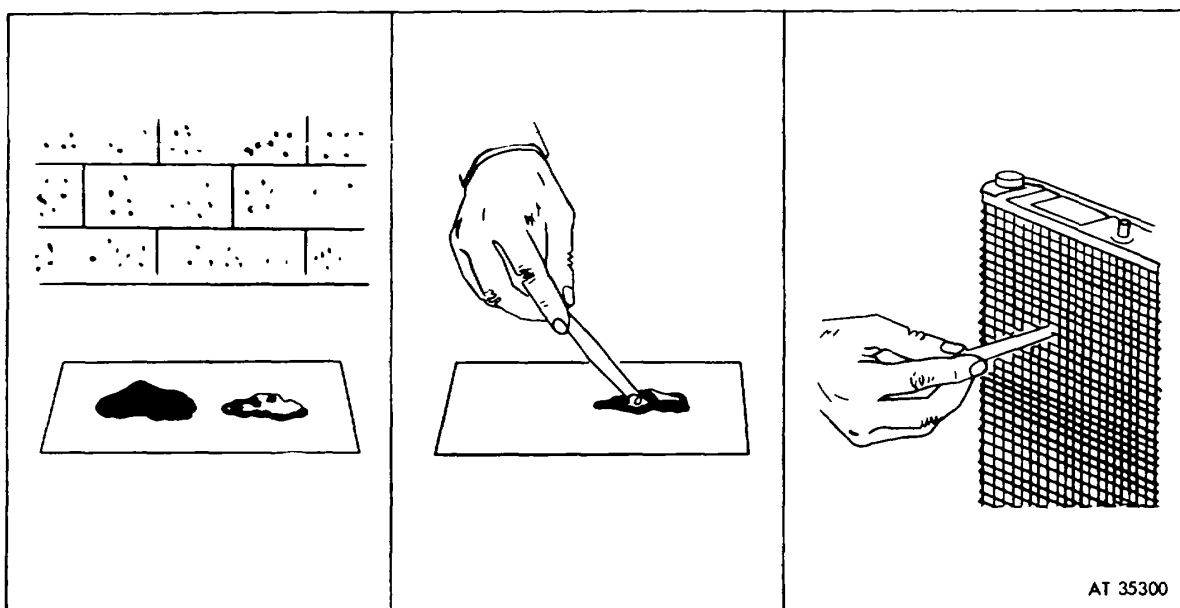

Figure 3-29. Simplified epoxy repair.

f. The mixed compound can be applied with spatula, putty knife, mixing stick or other convenient means. When repairing a leak, apply epoxy to the repair area using a wiping and circular motion to remove any air bubbles. The epoxy compound should be applied to the entire area around the leak. In general, extremely thick quantities will add nothing to the effectiveness of the repair.

g. Holes, gaps or structural repairs may require reinforcing with glass tape, aluminum screening or other approved material. When reinforcing is used, apply epoxy compound to both sides of the reinforcement until it is saturated. The reinforcement should then be placed over the repair area and covered with additional epoxy compound. For increased strength use alternate layers of epoxy compound and reinforcing material.

h. Replace removed fins before curing so fins will be bonded. Narrow strips of aluminum sheet can be used for replacement fins. Hand crimp the sheet with duck bill pliers. If care is used, the crimping will resemble the original fins.

i. Allow epoxy to cure at room temperature for approximately two hours. After curing, the epoxy may be sanded, filed or machined.

j. Leak test radiator at required air pressure. Tools used to apply epoxy may be cleaned with lacquer thinner, acetone, methyl ketone or xylene before epoxy sets up.

INDEX ALPHABETICAL

A

	<i>Paragraph</i>	<i>Page</i>
Accessories connected to cooling system	2-15	2-11
Accessory systems, engine	1-22	1-10
Air leak test	3-19	3-7
Aluminum radiator repair	3-41	3-20
Anti freeze protection	2-29	2-22
Antifreeze	2-29 <i>b</i>	2-23
Antifreeze installation	2-29 <i>d</i>	2-23
Antifreeze protection	2-29 <i>c</i>	2-23
Antifreeze testing	2-29 <i>f</i>	2-24
Freezing damage	2-29 <i>a</i>	2-22
Slush freeze-up	2-29 <i>e</i>	2-24

B

Belts (See drive belts)		
Blocking tubes	3-35	3-18
Boiling and evaporation	2-28	2-20
After-boil	2-28 <i>e</i>	2-22
During engine operation	2-28 <i>d</i>	2-22
Effect of pressure In the cooling system	2-28 <i>c</i>	2-21
Effect on altitude	2-28 <i>b</i>	2-20
Evaporation	2-28 <i>f</i>	2-22
Nature of boiling	2-28 <i>a</i>	2-20
Boiling out radiator	3-11	3-6

C

Cleaning	3-6	3-3
Cleaning and painting	3-23	3-9
Cleaning solutions	3-12	3-6
Cleaning tool	3-15	3-6
Clogging, determining extent of	3-7	3-3
Combustion leak test	3-21	3-8
Components of cooling system	1-4	1-1
Coolant examination	2-19	2-14
Coolant level	2-20	2-15
Coolant level checking	2-20 <i>a</i>	2-15
Coolant level as indicator of cooling system conditions	2-20 <i>c</i>	2-15
Coolant shortage	2-20 <i>b</i>	2-15
Operator's responsibility	2-20 <i>f</i>	2-15
Overfilling	2-20 <i>e</i>	2-15
Standard coolant level maintenance	2-20 <i>d</i>	2-15
Coolant operating temperature	2-18	2-14
General	2-18 <i>a</i>	2-14
Overcooling difficulties	2-18 <i>c</i>	2-14
Overheating difficulties	2-18 <i>b</i>	2-14
Temperature gage observation	2-18 <i>d</i>	2-14
Coolants	2-33	2-26
Approved coolants	2-33 <i>a</i>	2-26
Unapproved coolants	2-33 <i>b</i>	2-26
Use of engine cooling system cleaning compound	2-33 <i>c</i>	2-26
Cooling system corrosion	2-16	2-11
Contributing causes	2-16 <i>b</i>	2-12
Corrosion damage	2-16 <i>d</i>	2-13
Effects of rust formation	2-16 <i>c</i>	2-12
Rust formation	2-16 <i>a</i>	2-11
Core hole plugs	1-7 <i>c</i>	1-4
Core, radiator	3-3	3-2
Major repairs	3-39	3-19
Corrosion inhibitors	2-32	2-26
Antifreeze reinhibitor	2-32 <i>d</i>	2-26
Conservation of antifreeze	2-32 <i>g</i>	2-26
Effect of operation on antifreeze inhibitors	2-32 <i>f</i>	2-26

Inhibitor for water	2-32e	2-26
Inhibitor in antifreeze	2-32c	2-26
Nature of corrosion inhibitors	2-32b	2-26
The corrosion problem	2-32a	2-26
Cylinder head joint.....	1-14, 2-13	1-8, 2-10
Causes and effects of leakage	2-13a	2-10
Cylinder head gasket	1-14b	1-8
Prevention of leakage	2-13b	2-11
Water transfer ports	1-14a	1-8
D		
Drain cocks	1-7a	1-3
Drive belts	1-5a	1-3
Drive shafts	1-5b	1-3
Drying	3-10	3-5
E		
Electrical system	1-22d	1-11
Engine accessory systems	1-22	1-10
Electrical system	1-22d	1-11
Exhaust system.....	1-22c	1-11
Fuel system	1-22b	1-10
Engine assembly	1-23	1-11
Engine block flushing	3-8	3-3
Engine cooling problems in military operation	2-4	2-4
Engine lubricating system	1-21	1-10
Engine temperature gage	1-16	1-9
Engine water jacket.....	1-15, 2-14	1-8, 2-11
Construction	1-15a	1-8
Function and operation	1-15b	1-8
F		
Fan and drive belts	2-8	2-6
Drive belts	2-8b	2-6
Fan and shroud.....	1-8	1-4
Fan.....	1-8a	1-4
Shroud	1-8b	1-4
Field test tank	3-25	3-9
Fins, replacing	3-33	3-15
Fittings	1-7, 3-5	1-3, 3-3
Flo testing	3-9	3-4
Flo tester	3-18	3-6
Flushing	3-8	3-3
Forms and records.....	1-2	1-1
Fuel system	1-22	1-10
G		
Gaskets.....	1-19	1-10
H		
Header, patching	3-36	3-18
Header, removing and replacing.....	3-31	3-14
Header repair	3-28	3-10
Header top repair	3-27	3-10
Hoses.....	1-6	1-3
L		
Leakage	2-5	2-4
Leak testing, air	3-19	3-7
Leak testing, combustion	3-21	3-8
Lubricating system.....	1-21	1-10
M		
major core repairs	3-39	3-19
Mounting assembly, radiator.....	3-40	3-20
Miscellaneous fittings.....	1-7	1-3
N		
Neck, filler, radiator, repair.....	3-38	3-19

O

	<i>Paragraph</i>	<i>Page</i>
Other fittings	1-7 <i>d</i>	1-4
Overflow pipes, removing and replacing	3-37	3-19
Overflow tank	1-11,2-11	1-5,2-8

P

Painting	3-23	3-9
Patching headers and tanks	3-36	3-18
Pipes, hoses, and connections	1-6	1-3
Prevention of rust and corrosion	2-17	2-13
Inhibitors	2-17 <i>a</i>	2-13
Inhibitor in antifreeze	2-17 <i>b</i>	2-14
Inhibitor for water	2-17 <i>c</i>	2-14
Rust prevention vs cleaning or replacement	2-17 <i>d</i>	2-14
Preventive maintenance	2-3	2-4
Preventive cleaning	2-21	2-15
Cleaning	2-21 <i>d</i>	2-16
Cleaning compound	2-21 <i>b</i>	2-16
Coolant service	2-21 <i>i</i>	2-17
Engine temperature	2-21 <i>c</i>	2-16
General	2-21 <i>a</i>	2-15
Inhibiting	2-21 <i>f</i>	2-16
Leaks	2-21 <i>h</i>	2-17
Normal flushing	2-21 <i>e</i>	2-16
Pressure flushing	2-21 <i>g</i>	2-16
Preventive maintenance	2-30	2-24
Properties of antifreeze compound solution	2-31	2-24

R

Radiator	1-9, 2-10	1-4, 2-7
Air passage obstruction	2-10 <i>b</i>	2-8
Boiling out	3-11	3-6
Cleaning	3-6	3-3
Cleaning tool	3-15	3-6
Construction	3-1	3-1
Coolant	2-25	2-20
Core construction	1-9 <i>c</i>	1-4
Core function	1-9 <i>d</i>	1-5
Drying	3-10	3-5
Fittings	3-5	3-3
Flushing	3-8	3-3
Function of tanks	1-9 <i>b</i>	1-4
Leakage and failure	2-10 <i>a</i>	2-7
Opening neck repair	3-38	3-19
Pressure cap	1-10, 2-9	1-5,2-6
Repair	3-26	3-10
Rod cleaning	3-13	3-6
Supports	3-4	3-2
Testing	3-16	3-6
Radiator overflow tank	1-11, 2-11	1-5, 2-8
Causes of failure	2-11 <i>b</i>	2-8
Construction	1-11 <i>b</i> , 3-1	1-5, 3-1
Effects of failure	2-11 <i>c</i>	2-8
Function	2-11 <i>a</i>	2-8
General	1-11 <i>a</i>	1-5
Operation	1-11 <i>c</i>	1-6
Prevention of failure	2-11 <i>d</i>	2-8
Removing and replacing overflow pipes	3-37	3-19
Radiator opening neck repair	3-38	3-19
Radiator pressure cap	2-9, 1-10	2-6, 1-5
Causes of failure	2-9 <i>b</i>	2-7
Effects of failure	2-9 <i>c</i>	2-7
Function	1-10 <i>b</i>	1-5
General	1-10 <i>a</i>	1-5
Handling and maintenance	2-9 <i>d</i>	2-7
Importance of proper operation	2-9 <i>a</i>	2-6

	<i>Paragraph</i>	<i>Page</i>
Operation	1-10c	1-5
Testing	3-22	3-9
Reinforcements, tube	3-27c	3-10
Removing and replacing headers	3-31	3-14
Removing and replacing tanks	3-30	3-11
Removing and replacing tubes	3-32	3-14
Repairs	3-26	3-10
Reporting of errors	1-3	1-1
Resolder entire header	3-28, 3-29	3-10, 3-11
Resolder heater top corners	3-27	3-10
Rod cleaning	3-13	3-6
Rubber hose	2-6	2-5
Repairing tubes	3-34	3-18
S		
Scope	1-1	1-1
Shroud	1-8	1-4
Shutters, screens, etc	1-18	1-10
Special instructions	2-22	2-17
Special tools and equipment	2-2	2-1
Splicing tubes	3-33	3-15
Spray cleaning	3-14	3-6
Stand, testing	3-24	3-9
Steam escape and recirculation tubes	1-7b	1-4
Supports	3-4	3-2
T		
Tanks, patching	3-36	3-18
Tanks, removing and replacing	3-30	3-11
Temperature gage	1-16	1-9
Test tank, collapsible	3-25	3-9
Testing stand	3-24	3-9
Testing	3-16	3-6
Thermal expansion	2-27	2-20
Thermostat	1-12, 2-7	1-6, 2-5
By-pass	1-12d	1-7
Causes of failure	2-7a	2-5
Construction	1-12b	1-6
Effects of failure	2-7b	2-6
General	2-12a	1-6
Operation	1-12c	1-7
Temperature gage check on thermostat operation	2-7c	2-6
Tools and equipment	2-1	2-1
Troubleshooting	2-23	2-19
Tubes, blocking	3-35	3-18
Tubes, removing and replacing	3-32	3-14
Tubes, repairing	3-34	3-18
Tubes, splicing	3-33	3-15
V		
"V" test tank	3-30e	3-13
Vat cleaning	3-9	3-4
Visual inspection	3-17	3-6
W		
Water as a coolant	2-26	2-20
Water distribution tube	1-17	1-9
Water jacket	1-15, 2-14	1-8, 2-11
Water pump	1-13, 2-12	1-8, 2-8
Construction, general	1-13b	1-8
Effects of failure and leakage	2-12c	2-9
General	1-13a	1-8
Leakage	2-12b	2-9
Packless-type	1-13	1-8
Prevention service	2-12d	2-10
Pumping failure	2-12a	2-8
Water tanks	3-2	3-1
Water test	3-20	3-8

By Order of the Secretary of the Army

Official:

VERNE L BOWERS,
*Major General, United States Army,
The Adjutant General.*

W C. WESTMORELAND,
*General, United States Army,
Chief of Staff*

Distribution:

To be distributed in accordance with DA Form 12-38, (qty rqr block No 250) organizational maintenance requirements for Truck, utility, 1/4 Ton, M151.

U. S. GOVERNMENT PRINTING OFFICE: 1996 - 406-421/53173

RECOMMENDED CHANGES TO EQUIPMENT TECHNICAL PUBLICATIONS



THEN... JOT DOWN THE DOPE ABOUT IT ON THIS FORM, CAREFULLY TEAR IT OUT, FOLD IT AND DROP IT IN THE MAIL!

SOMETHING WRONG WITH THIS PUBLICATION?

FROM: (PRINT YOUR UNIT'S COMPLETE ADDRESS)

DATE SENT

PUBLICATION NUMBER

PUBLICATION DATE

PUBLICATION TITLE

BE EXACT... PIN-POINT WHERE IT IS

PAGE NO.

PARA-GRAPH

FIGURE NO.

TABLE NO.

IN THIS SPACE TELL WHAT IS WRONG AND WHAT SHOULD BE DONE ABOUT IT:

TEAR ALONG PERFORATED LINE

PRINTED NAME, GRADE OR TITLE, AND TELEPHONE NUMBER

SIGN HERE:

DA FORM 2028-2
1 JUL 79

PREVIOUS EDITIONS ARE OBSOLETE.

P.S.—IF YOUR OUTFIT WANTS TO KNOW ABOUT YOUR RECOMMENDATION MAKE A CARBON COPY OF THIS AND GIVE IT TO YOUR HEADQUARTERS.

THE METRIC SYSTEM AND EQUIVALENTS

WEIGHT MEASURE

1 Centimeter = 10 Millimeters = 0.01 Meters = 0.3937 Inches
 1 Meter = 100 Centimeters = 1000 Millimeters = 39.37 Inches
 1 Kilometer = 1000 Meters = 0.621 Miles

WEIGHTS

1 Gram = 0.001 Kilograms = 1000 Milligrams = 0.035 Ounces
 1 Kilogram = 1000 Grams = 2.2 lb.
 1 Metric Ton = 1000 Kilograms = 1 Megagram = 1.1 Short Tons

LIQUID MEASURE

1 Milliliter = 0.001 Liters = 0.0338 Fluid Ounces
 1 Liter = 1000 Milliliters = 33.82 Fluid Ounces

SQUARE MEASURE

1 Sq. Centimeter = 100 Sq. Millimeters = 0.155 Sq. Inches
 1 Sq. Meter = 10,000 Sq. Centimeters = 10.76 Sq. Feet
 1 Sq. Kilometer = 1,000,000 Sq. Meters = 0.386 Sq. Miles

CUBIC MEASURE

1 Cu. Centimeter = 1000 Cu. Millimeters = 0.06 Cu. Inches
 1 Cu. Meter = 1,000,000 Cu. Centimeters = 35.31 Cu. Feet

TEMPERATURE

$5/9(^{\circ}\text{F} - 32) = ^{\circ}\text{C}$
 212° Fahrenheit is equivalent to 100° Celsius
 90° Fahrenheit is equivalent to 32.2° Celsius
 32° Fahrenheit is equivalent to 0° Celsius
 $9/5^{\circ}\text{C} + 32 = ^{\circ}\text{F}$

APPROXIMATE CONVERSION FACTORS

TO CHANGE	TO	MULTIPLY BY
Inches	Centimeters	2.540
Feet	Meters	0.305
Yards	Meters	0.914
Miles	Kilometers	1.609
Square Inches	Square Centimeters	6.451
Square Feet	Square Meters	0.093
Square Yards	Square Meters	0.836
Square Miles	Square Kilometers	2.590
Acres	Square Hectometers	0.405
Cubic Feet	Cubic Meters	0.028
Cubic Yards	Cubic Meters	0.765
Fluid Ounces	Milliliters	29.573
its	Liters	0.473
arts	Liters	0.946
allons	Liters	3.785
Ounces	Grams	28.349
Pounds	Kilograms	0.454
Short Tons	Metric Tons	0.907
Pound-Feet	Newton-Meters	1.356
Pounds per Square Inch	Kilopascals	6.895
Miles per Gallon	Kilometers per Liter	0.425
Miles per Hour	Kilometers per Hour	1.609

TO CHANGE	TO	MULTIPLY BY
Centimeters	Inches	0.394
Meters	Feet	3.280
Meters	Yards	1.094
Kilometers	Miles	0.621
Square Centimeters	Square Inches	0.155
Square Meters	Square Feet	10.764
Square Meters	Square Yards	1.196
Square Kilometers	Square Miles	0.386
Square Hectometers	Acres	2.471
Cubic Meters	Cubic Feet	35.315
Cubic Meters	Cubic Yards	1.308
Milliliters	Fluid Ounces	0.034
Liters	Pints	2.113
Liters	Quarts	1.057
ers	Gallons	0.264
ms	Ounces	0.035
ograms	Pounds	2.205
Metric Tons	Short Tons	1.102
Newton-Meters	Pounds-Feet	0.738
Kilopascals	Pounds per Square Inch	0.145
ometers per Liter	Miles per Gallon	2.354
ometers per Hour	Miles per Hour	0.621



PIN: 014037 - 002